



Sizing Deck Footings

Don't guess at your deck footings. Dig in and figure it out.

BY MIKE GUERTIN

Footings transfer the weight of a deck and its occupants to the ground. How many footings you need and how big to make them is specific to each deck. Doing the calculations takes only a few minutes, ensures that I'm following best building practices, and keeps me from digging more than necessary.

The size and spacing of footings tie directly to the maximum spacing between posts of the beam they support. A larger beam can span a greater distance, requiring fewer but larger footings. The American Wood Council publishes the *Prescriptive Residential Wood Deck Construction Guide*, which is based on the International Residential Code (IRC). Commonly referred to as DCA-6 (awc.org/Publications/DCA/DCA6/DCA6-09.pdf), it contains tables for sizing deck beams. The DCA-6 assumes a 40-lb.-per-sq.-ft. (psf) live load and a 10-psf dead

load. (Live load is the weight of occupants and furniture, while dead load is the weight of the structure.) Although the DCA-6 tables are valid in most jurisdictions, snow loads (found in the IRC) in northern New England or the Western mountains may exceed 40 psf, and you'll need to substitute that for the live load. Some local building codes may also require designing to a greater live load. In either case, you may then require an engineer's help.

Knowing the total load in psf, the size of the deck, and the number of footings, I can calculate what each footing has to support. The footing size is based on this load and the bearing capacity of the soil.

Editorial adviser Mike Guertin is a contractor in East Greenwich, R.I. Photos by Dan Thornton, except where noted.

CHOOSE A BEAM

Several factors determine which beam setup to use. Should it overhang the end posts or end flush with them? Is there a backhoe at hand so that digging a few large footings makes sense? Or is this deck on a house with established landscaping that calls for a greater number of smaller-diameter footings that can be dug by hand around obstructions? What is the joist span?

After answering those questions, I choose a beam configuration, such as a double 2x8, from the DCA-6 table and determine the number of footings needed based on the size of the deck.

I prefer a double 2x beam because it can rest on notched 6x6 posts. The 2½-in.-thick leg on the back of the notch bolts to the beam. Triple 2x beams sometimes make sense, but they require a structural connector to join to the post.

The DCA-6 table allows joist overhangs (cantilevers) past the beam of up to one-quarter of the span between the beam and the ledger. The beams themselves can overhang the end posts by one-quarter of the post spacing. By cantilevering the end of the beam, you often can eliminate one footing.

Three beam options for a 14-ft. by 20-ft. deck

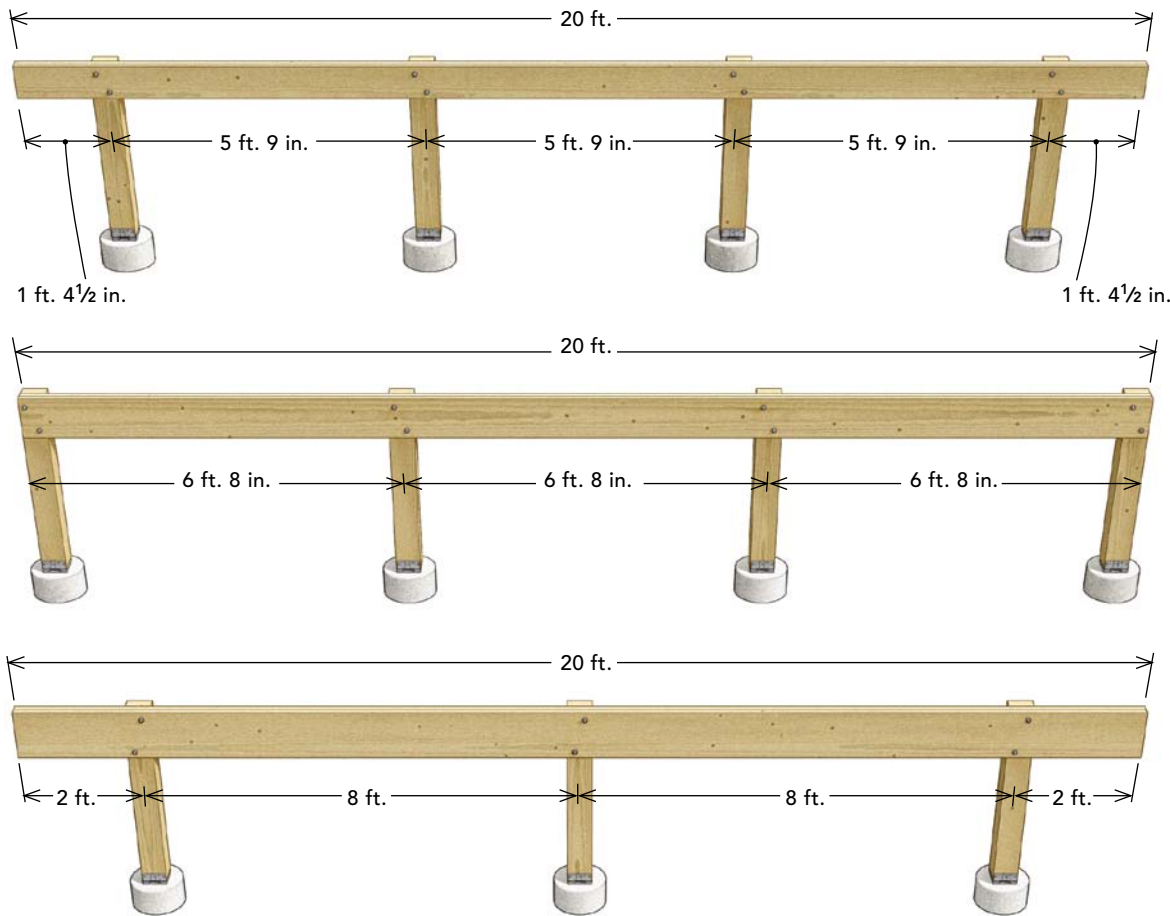

A double 2x8 beam offers a maximum span of 5 ft. 9 in. and a maximum overhang of 1 ft. 5¼ in., resulting in four posts spaced 5 ft. 9 in. apart and overhangs of 1 ft. 4½ in. at the ends.

A double 2x10 beam with a maximum span of 6 ft. 9 in. results in four footings spaced 6 ft. 8 in. apart.

A double 2x12 beam with a maximum span of 8 ft. and a maximum overhang of 2 ft. results in four posts spaced 8 ft. apart and overhangs of 2 ft. at the ends.

Post spacing for southern-pine beams

Beam size	Joist spans less than or equal to:							
	6 ft.	8 ft.	10 ft.	12 ft.	14 ft.	16 ft.	18 ft.	
2-2x8	8 ft. 9 in.	7 ft. 7 in.	6 ft. 9 in.	6 ft. 2 in.	5 ft. 9 in.	5 ft. 4 in.	5 ft. 0 in.	
	10 ft. 4 in.	9 ft. 0 in.	8 ft. 0 in.	7 ft. 4 in.	6 ft. 9 in.	6 ft. 4 in.	6 ft. 0 in.	
	12 ft. 2 in.	10 ft. 7 in.	9 ft. 5 in.	8 ft. 7 in.	8 ft. 0 in.	7 ft. 6 in.	7 ft. 0 in.	
3-2x8	10 ft. 10 in.	9 ft. 6 in.	8 ft. 6 in.	7 ft. 9 in.	7 ft. 2 in.	6 ft. 8 in.	6 ft. 4 in.	
	13 ft. 0 in.	11 ft. 3 in.	10 ft. 0 in.	9 ft. 2 in.	8 ft. 6 in.	7 ft. 11 in.	7 ft. 6 in.	
	15 ft. 3 in.	13 ft. 3 in.	11 ft. 10 in.	10 ft. 9 in.	10 ft. 0 in.	9 ft. 4 in.	8 ft. 10 in.	

*Area depicted above

CALCULATE THE LOAD ON EACH FOOTING

The IRC calls for decks to be designed for a minimum 40-psf live load and a 10-psf dead load; add the two together for a total load of 50 psf. Each footing carries the load imposed by a tributary area of the deck whose depth is half the distance from the beam to the ledger (7 ft. in the example here), plus any cantilever of the joists beyond the beam (2 ft. here, for a total of 9 ft.). The width of each tributary area is the sum of half the distance from that footing to the footings on each side. The two end footings are a little different, though. They carry the load halfway to the next footing, plus any overhang of the beam. So while the tributary area of the two middle footings has a width of 5 ft. 9 in., that of the two end footings is only 4 ft. 3 in.

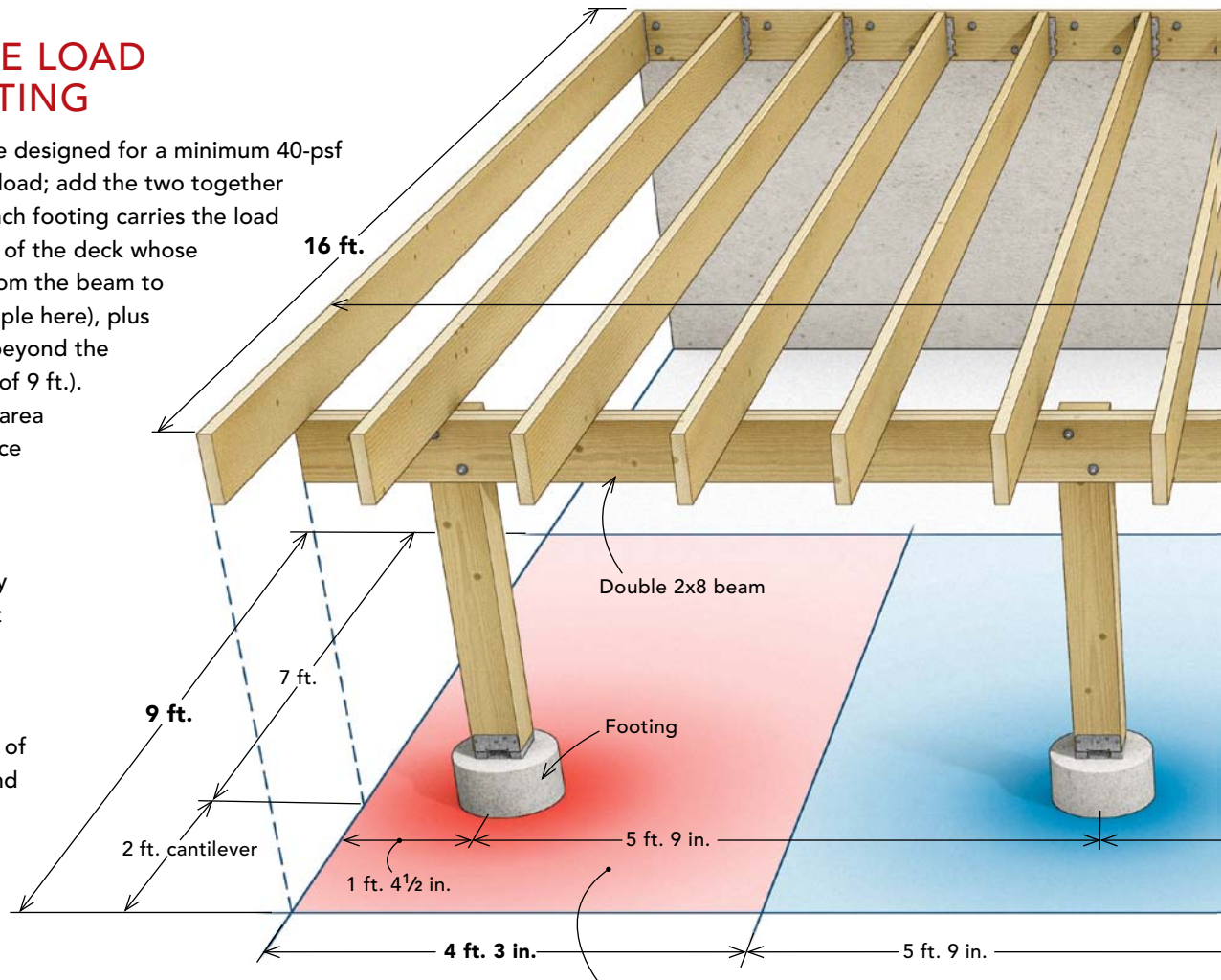

End-footing tributary area = 9 ft. x 4 ft. 3 in. = 38.25 sq. ft.
 End-footing tributary load = 38.25 sq. ft. x 50 psf = 1912.5 lb.



CARDBOARD TUBE FORMS CAN HANDLE SOME LOADS

Cylindrical cardboard tubes are the go-to footing forms for a lot of deck builders. These forms create smooth sides that reduce the chance of frost attaching to the concrete and heaving the footing, and they isolate the concrete from the surrounding soil to prevent it from mixing in and weakening the concrete. Here's a quick guide to the area of typical footing-form tubes and footing bearing capacity based on common soil load-bearing values.

Footing-form diameter	Area	1500-psf soil capacity	3000-psf soil capacity	4000-psf soil capacity
8 in.	50.3 sq. in. (0.3493 sq. ft.)	524 lb. per footing	1048 lb. per footing	1397 lb. per footing
10 in.	78.5 sq. in. (0.54514 sq. ft.)	818 lb. per footing	1635 lb. per footing	2180 lb. per footing
12 in.	113.1 sq. in. (0.7854 sq. ft.)	1178 lb. per footing	2356 lb. per footing	3142 lb. per footing

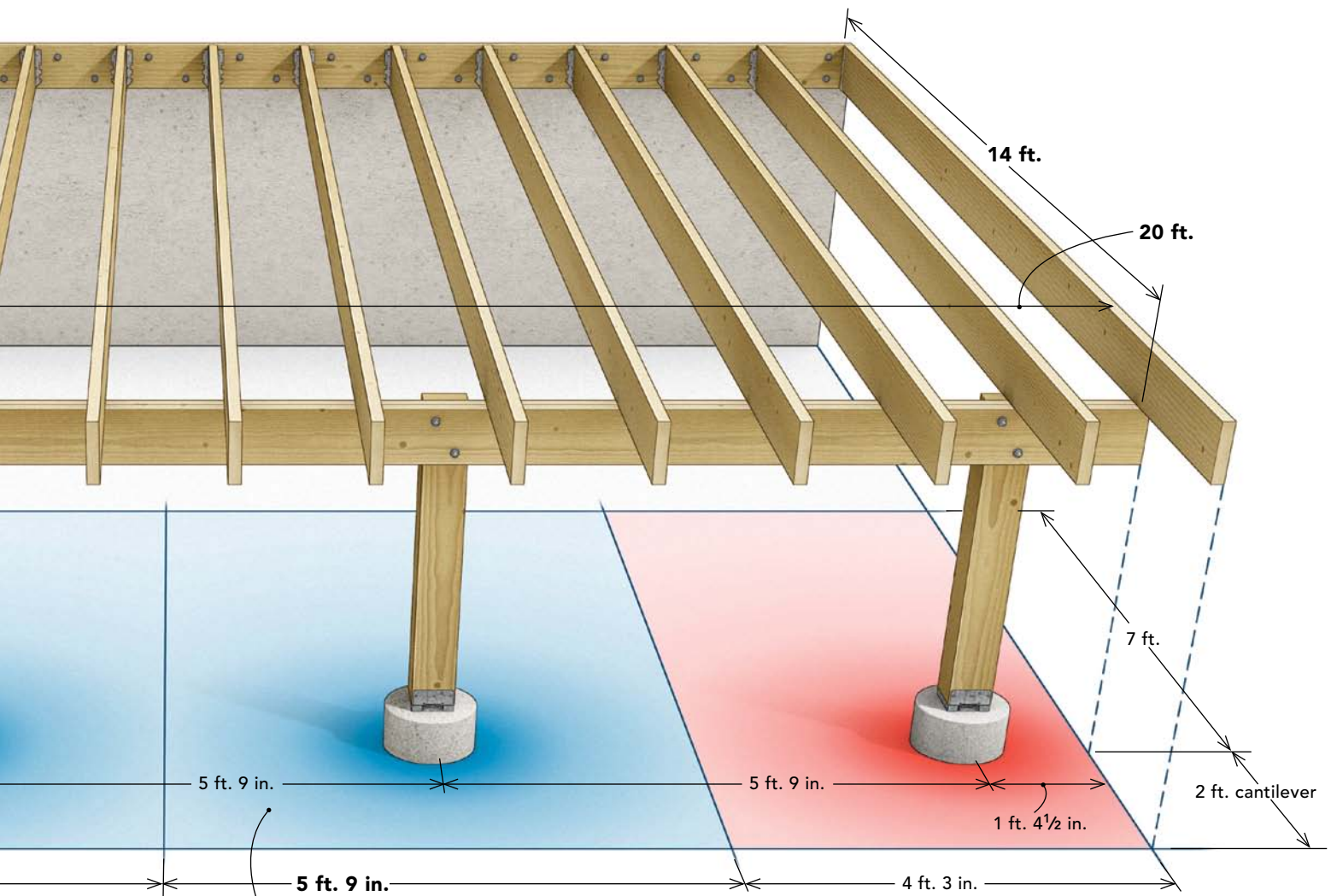

Center-footing tributary area = 9 ft. × 5 ft. 9 in. = 51.75 sq. ft.
 Center-footing tributary load = 51.75 sq. ft. × 50 psf = 2587.5 lb.

Bigger footing forms

The original form. The Bigfoot is a plastic form that fits the end of a standard cardboard tube. The company also offers an entirely plastic alternative (shown) said to be less susceptible to frost heave.
bigfootsystems.com

It's square. The Square Foot forms, which work with cardboard tubes, make it easy to calculate the area of the footing.
soundfootings.com



Designed for rebar. The WP Fail-Safe form incorporates a proprietary rebar system, particularly useful in areas with seismic and wind-uplift concerns.
wpfailsafe.com



Duct-tape compatible. The Redibase form is used with standard cardboard tubes. It's designed to allow the joint to be sealed easily with duct tape to keep dirt out of the form.
redibase-form.com



Tapered tube. The Footing Tube includes a concrete-saving tapered plastic tube in addition to the bell-shaped footing form. It offers little bite for ice to grab and lift, and it allows backfill to be compacted prior to placing the concrete.
foottube.com



SIZE THE FOOTINGS

Not all dirt is created equal. You need to know the bearing capacity of your soil before calculating footing size. The IRC lists the bearing capacity of five soil types, from "crystalline bedrock" at 20,000 psf down to 1500 psf for "firm fine sand, silty sand, and silty gravel." Your building department may have soil maps that show local soil types and their bearing capacity. You also can have an evaluation done by a soils engineer, but it's probably cheaper simply to use the IRC's default 1500-psf bearing capacity and to increase the size of the footings a little. Whether you're able to use cardboard tube forms or need to use one of the larger footing forms, odds are that there won't be forms for the exact footing size you calculate. In that case, always go to the next-larger form size.

Calculate the footing area needed. Once you know the load a footing will support and the bearing capacity of the soil, you can determine the required footing size.

Total load ÷ bearing capacity = area



Convert the area into square inches.

End footings

1912.5 lb. ÷ 1500 psf = 1.275 sq. ft.
1.275 sq. ft. × 144 = **183.6 sq. in.**

Center footings

2587.5 lb. ÷ 1500 psf = 1.725 sq. ft.
1.725 sq. ft. × 144 = **248.4 sq. in.**

Convert the area into a round footing diameter or a square footing size.

$2 \sqrt{\text{area} \div \pi}$ = diameter of round footing ($\pi = 3.14$)
or $\sqrt{\text{area}}$ = length of sides of a square footing

End footings

Round: $2 \sqrt{(183.6 \div 3.14)} = 15.29$ in. ($15\frac{5}{16}$ in.) dia.
Square: $\sqrt{183.6} = 13.55$ sq. in. ($13\frac{9}{16}$ in.)

Center footings

Round: $2 \sqrt{(248.4 \div 3.14)} = 17.79$ in. ($17\frac{3}{4}$ in.) dia.
Square: $\sqrt{248.4} = 15.76$ sq. in. ($15\frac{3}{4}$ in.)

Frostlines and soil type affect footing depth.

In areas not subject to freezing, footings must be at least 12 in. below the undisturbed ground surface. If there is any fill where the footings are placed, the footing holes must be dug at least 12 in. below the fill or disturbed soil into suitable ground. Compressive soil, expansive soil, and organic soil are a few common unsuitable types. Footing holes have to be dug through unsuitable soil to reach stable soil. When placed within 5 ft. of a house, footings must be at least the same depth as the house foundation to be sure they rest on undisturbed ground. Where the ground freezes, footings must be at least as deep as the local frostline. Your building department will know what this is, but it can be as deep as 60 in.



Footing-to-post connection

The post is tied to the footing with a connector such as a Simpson ABA66Z or a USP PA66E-TZ, combined with a concrete anchor bolt.

Cast in place.
Standard foundation bolts are a common way to attach post bases, but they must be placed accurately in the wet concrete.



Glued in place.
Chemical anchors that glue anchor bolts into drill holes offer great strength. Chemical anchors must be at least 3³/₁₆ in. from the footing edge.



Wedged in place.
Wedge bolts and sleeves fit into holes drilled after the concrete cures. Wedge anchors must be at least 5 in. from the concrete's edge.



Alternative footings

GARBAGE BAGS

I make adjustable footing forms from heavy-duty garbage bags. First, I dig a footing hole a little larger than the cardboard form and about 1 ft. shy of my final depth. Then I widen the bottom of the hole to the size required by the footing-size calculation.

Using duct tape, I attach a garbage bag to the bottom of the cardboard form and slip it into the hole. Before backfilling, I fill the bag with concrete so that it spreads out and fills the hole. At that point, I backfill the footing tube and fill the inside of the tube with concrete.



PIN FOOTINGS

Pin footings (pinfoundations.com) are engineered systems consisting of concrete anchor blocks cast with guide holes through which steel pins are driven diagonally into the earth. Each anchor block has an integral bolt on the top that is ready to accept post hardware. The pins are made of 1-in.-dia., schedule-40 galvanized steel. Residential models are sized for frost depths between 36 in. and 48 in., and commercial models can work with a 60-in. frost depth.

The residential models have a load capacity of 2700 lb. when installed in 1500-psf soil and 3600 lb. in 2000-psf soil. The pins are driven into the earth in just minutes using a 1¹/₈-in. hex-shank demolition hammer.



HELICAL PILES

In areas served by a specialty contractor, helical piers can save a lot of digging. Galvanized-steel assemblies consisting of a helical plate (typically 12 in. dia. for decks) and a 2-in. pipe, residential helical piles are driven by a hydraulic motor on a small, dedicated machine. Once the pile reaches the minimum depth allowed by code, the operator monitors the hydraulic pressure required to drive the pile, which directly translates to the bearing

capacity of the footing. Once the required bearing is reached, the pile is cut to length and a beam saddle is welded on. Depending on the contractor, you can end up with an engineer's report that verifies the load each footing can handle. One source for that service is technometalpost.com.

