

Improve Your Work With SketchUp

Here are the many ways one builder uses a free design program to avoid complications, to plan more efficiently, and to raise the quality of his work

BY MATT JACKSON

I admit it: I'm a tool junkie. I like good tools and enjoy exploring the ways that they can help me to work faster and more accurately. A free good tool is even better. While I prefer tools that help me to work on the job site or in the shop, I've always been open to trying any tool that promises to improve my work and save me and my clients money. The free version of Google's SketchUp is one such tool.

I should mention right away that I'm a carpenter through and through, not a techie. But the realization that I could upgrade at no cost from a stubby pencil and a framing square to 3-D digital drafting motivated me to learn how to use this program, and that move has paid off. Not only have I saved countless hours by avoiding potentially costly mistakes, but my work also is better. I'm able to think through the construction process as I design, which enables me to anticipate the

best technique for a task before I ever touch a saw, and my material takeoffs are more accurate, which means fewer trips to the lumberyard and less wasted material.

Of course, there is still a difference between the irregularity of real materials and site conditions and those in the digital world, where it doesn't rain, where boards are straight, and where the click of a mouse can make a 9-ft. board 12 ft. long.

Plan with accuracy

Many of my jobs include intricate details that require a lot of planning. Custom staircase geometry and complex, off-angle hip roofs are difficult to calculate and create on the fly. In the past, though, that's basically what I'd do: scratch some notes on a piece of paper, then start working with material. With tape measure and framing square in hand, I'd calculate as I built.

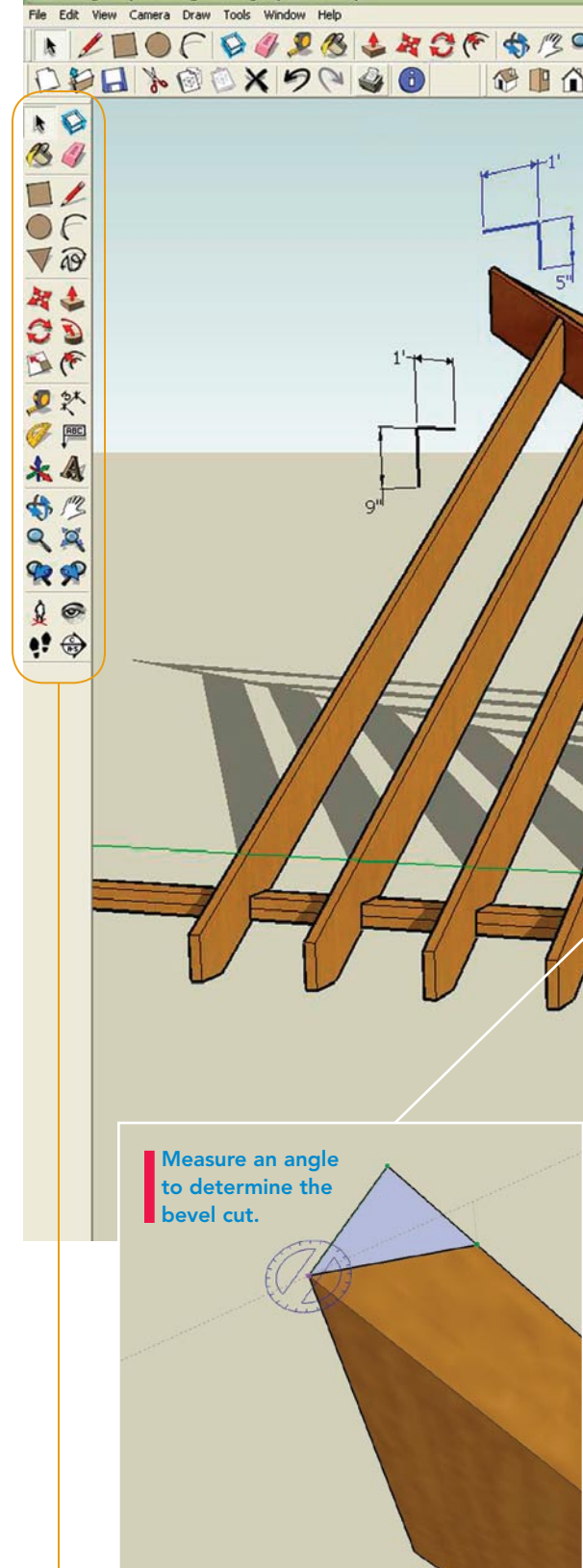

The virtual toolbox

SketchUp comes with a set of tools as useful as a compound-miter saw without the weight or price. Premade components such as 2x4s are available to download into a model as well. While there are too many tools to list, here are a few that you'll use often and an idea of what can be done with them.

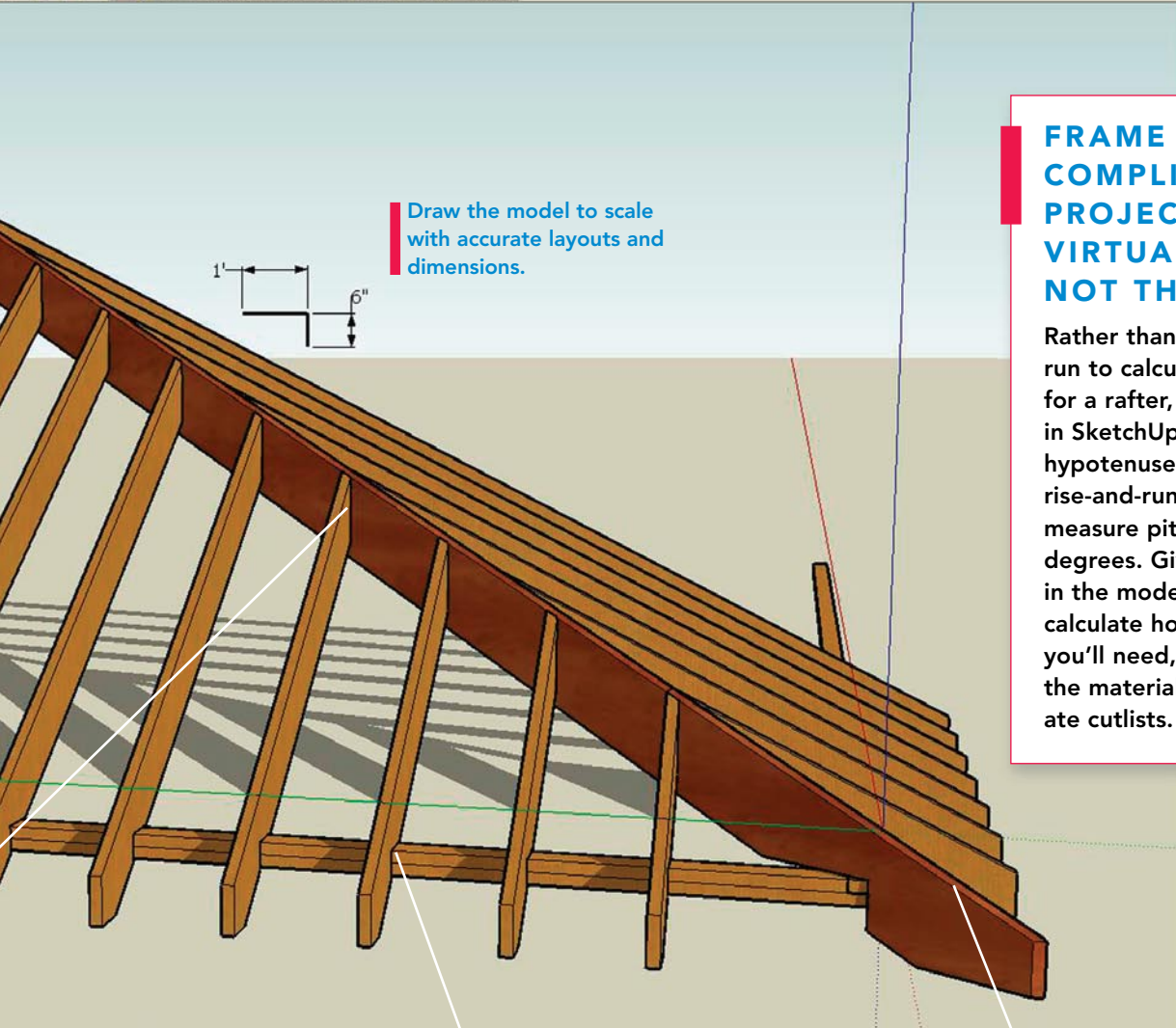

FRAME COMPLICATED PROJECTS IN A VIRTUAL WORLD, NOT THE REAL ONE

Rather than entering rise and run to calculate the hypotenuse for a rafter, draw the values in SketchUp, and measure the hypotenuse. Enter a given rise-and-run dimension, and measure pitch as a ratio or in degrees. Given the dimensions in the model, it's possible to calculate how much material you'll need, decide how to use the material efficiently, and create cutlists.

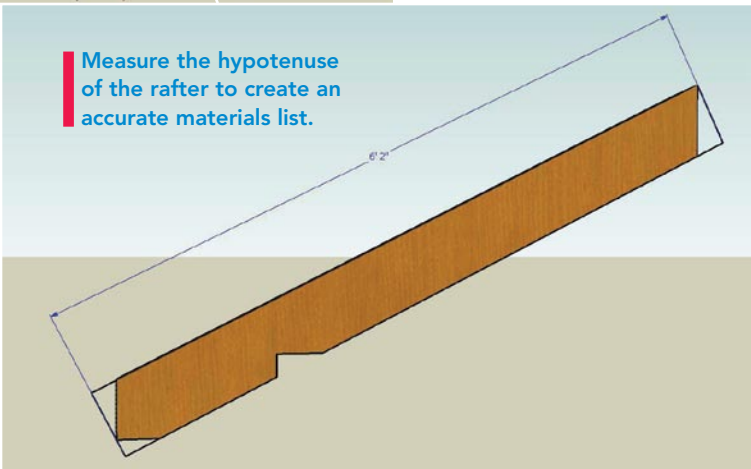
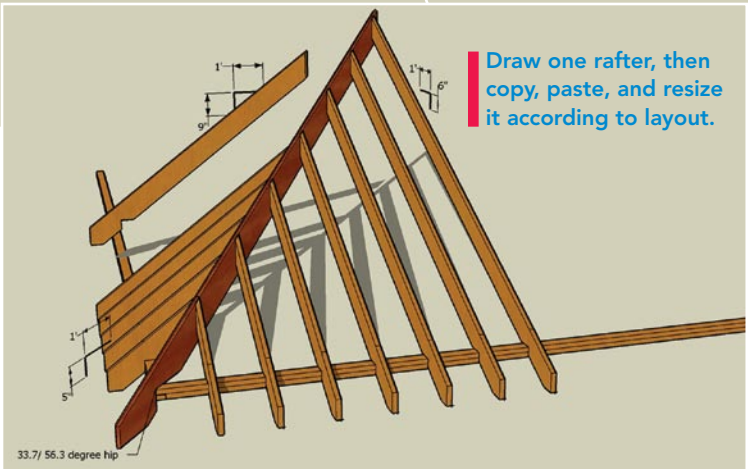

Push/pull
(aka board stretcher)
Once a 2-D object is drawn, push/pull allows you to make it 3-D and to change any of its dimensions. Make ½-in. plywood ¾ in. or a 2x4 into a 2x6 with the click and drag of a mouse.



Move
Move allows you to grab a component or a group of components and place them in a different location. Shift a cabinet face frame over ⅛ in., or change floor-joist layout from 16 in. to 24 in. on center.



Protractor
This virtual bevel square allows you to draw lines at any angle or to measure the angle you've drawn. Determine the roof pitch or find the bevel cut on a hip rafter.



Tape measure
Create guidelines and points at any necessary dimension. Lay out joists, studs, and rafters, or the rise and run of stairs.

SketchUp's 3-D modeling allows me to troubleshoot details as I create accurate renderings of a project. Best of all, once the model is finished, I can create a materials list and cutlists. On site, I have a detailed plan to refer to if and when I need to reorient myself to the project details.

Get the design details right

Many projects have started out as a sketch on a napkin at a coffeehouse. While this is a great way to kick around ideas, its limitations quickly become apparent when I'm trying to draw in scale. In the past, if I wanted to design a cornice detail that included crown, cove, bullnose, and dentil moldings, I would have to buy multiple sizes of each and make mock-ups until I found the one that worked the best. Sometimes I would have to take the mock-ups to the job site to make sure the proportions were right. This was time-consuming and a waste of material.

The ability to create virtual components makes this process simple. Once I build a cove profile, for example, I can change its size by clicking the scale tool and dragging the mouse. Once I've assembled a profile that seems to work, I can move pieces individually to create the reveal I need. With the orbit tool, I can see what the molding will look like from every view.

For planning a built-in bookcase, for example, I can create a model that shows different numbers and sizes of vertical shelf sections to decide what fits the space best. Getting a look at how many roof-support columns I need for a covered porch is another application for this feature. I also have used it to determine window sizes, proportions, and locations with a confidence that there will be no surprises for the homeowner once the project is complete.

Visualize the result

Customers frequently call me for design/build remodeling projects and aren't able to choose among different options. I've found that clients who aren't accustomed to looking at two-dimensional drawings have great difficulty knowing what a project will look like when it's complete. The photo-match feature of SketchUp has been invaluable in this situation.

Photo match allows me to photograph an existing space—a family room, for instance—and import the photo into the program. Once the photo is imported, I can do a 3-D model

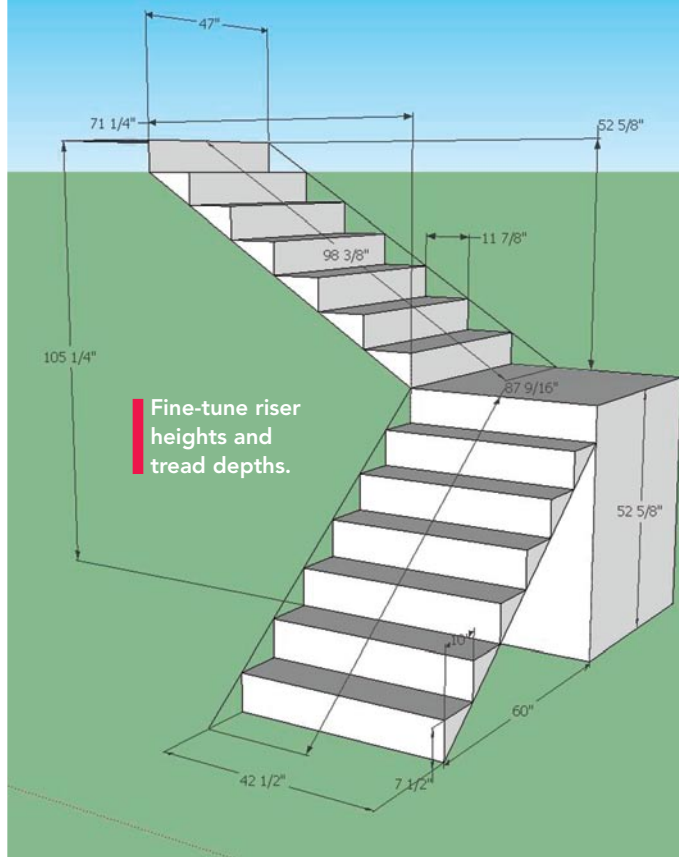

CALCULATE RISE AND RUN

Input the given rise and run of the space, and calculate everything you need to build stairs. Calculate the final rise and run with finished-floor heights to lay out stringers accurately, and to determine the tread width and the riser height.

VISUALIZE THE RESULT

With the photo-match feature, it's possible to draw to scale over a photo so that you can visualize the result. It's also possible to measure lines accurately in the photo. Add a dormer to scale, or change a window location. Once the photo is imported, move the axis points to get the right perspective. Build in that view to see how it will look when it's finished.

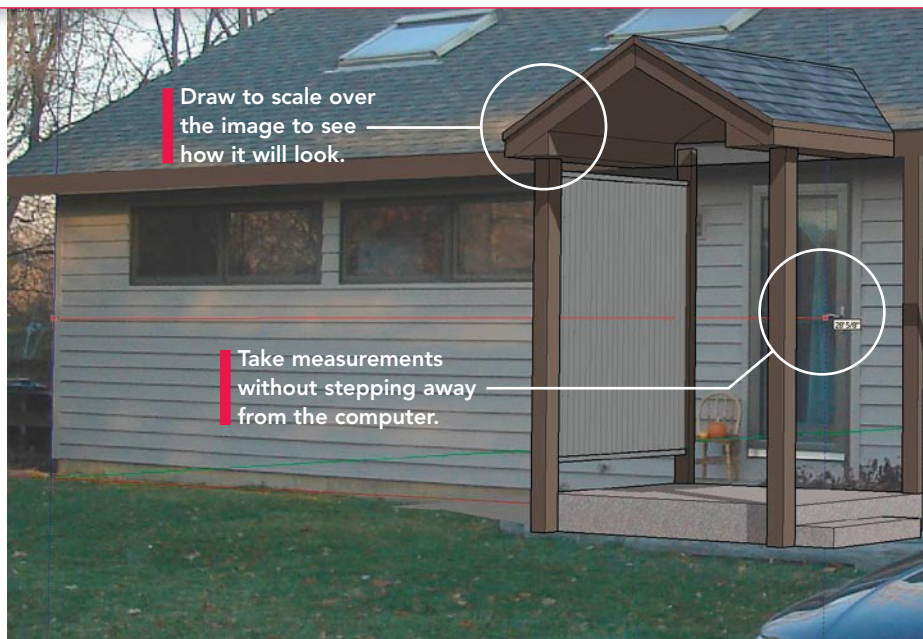

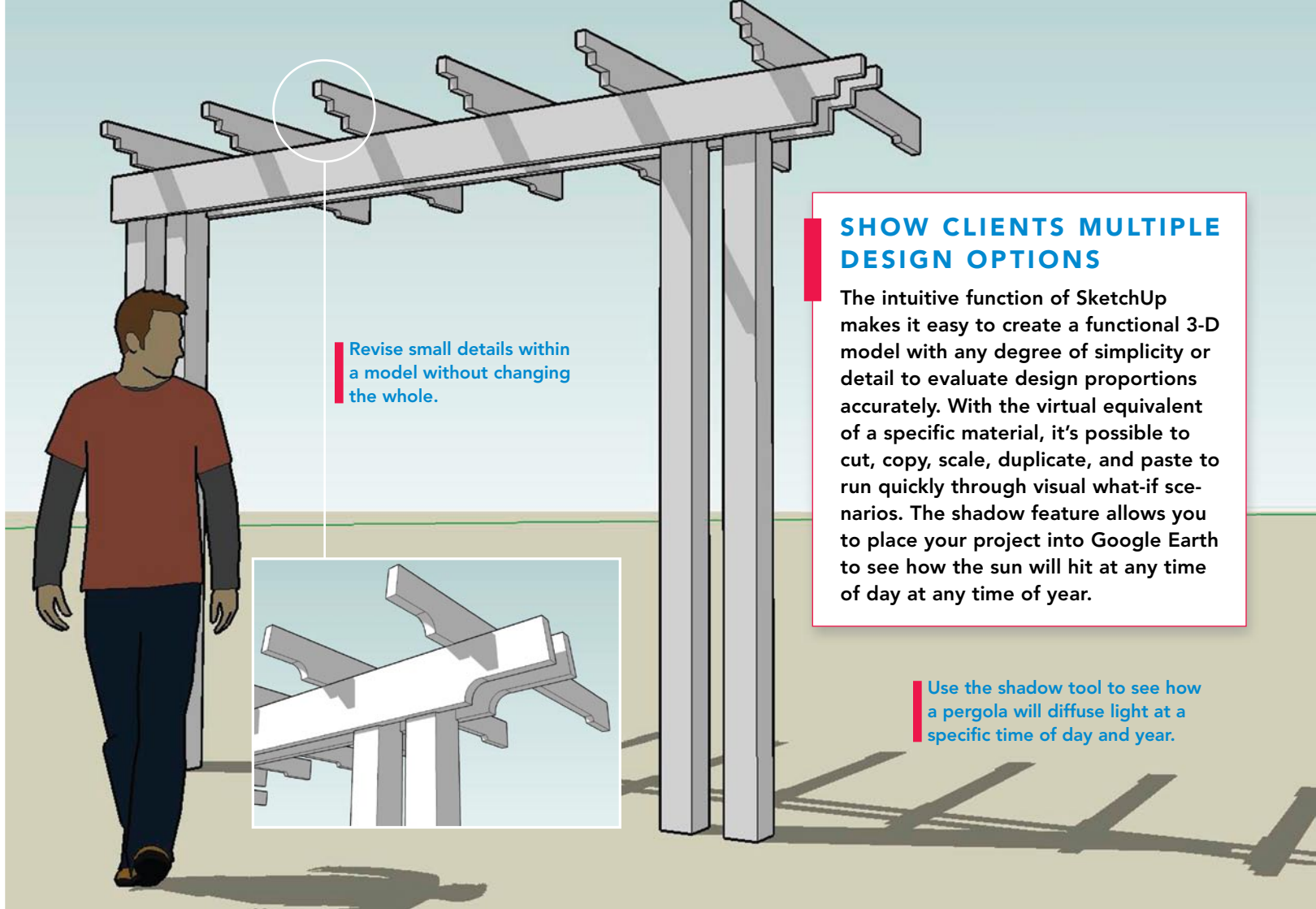

Revise small details within a model without changing the whole.

SHOW CLIENTS MULTIPLE DESIGN OPTIONS

The intuitive function of SketchUp makes it easy to create a functional 3-D model with any degree of simplicity or detail to evaluate design proportions accurately. With the virtual equivalent of a specific material, it's possible to cut, copy, scale, duplicate, and paste to run quickly through visual what-if scenarios. The shadow feature allows you to place your project into Google Earth to see how the sun will hit at any time of day at any time of year.

Use the shadow tool to see how a pergola will diffuse light at a specific time of day and year.

Do more at a price

While the free version of SketchUp is an incredible value, it has limitations. Generating multimedia presentations, for example, is a feature available only in SketchUp Pro, which costs \$495. Unlike the free version, SketchUp Pro also allows you to export 3-D models in several formats and print high-quality documents on any paper size.

Other architectural-design programs are available in versions for homeowners, contractors, designers, architects, and engineers, with prices to match the user's skill level. Basic versions offer many of the same functions as SketchUp, and more advanced versions come with hundreds more features. Chief Architect, for example, comes complete with libraries full of everything from ADA-compliant toilets to multiple sheet goods that can be dragged and dropped into a model and modified. Material prices can be added to create cost estimates. Material lists can be generated and listed by type. You also can produce plan sets with framing, elevation, cross sections, and 3-D overviews.



SOURCES

Chief Architect

\$49 to \$2195
www.chiefarchitect.com

Google SketchUp Pro 7.0

\$495
http://sketchup.google.com

Punch! Home & Landscape Design Suite

\$49 to \$499
www.punchsoftware.com

SoftPlan

\$985 to \$2385
www.softplan.com

TurboCAD

\$129 to \$1495
www.turbocad.com

Vectorworks Architect

\$1295 to \$2895
www.nemetschek.net

TWEAK THE DETAILS

Create numerous iterations of a design by changing the profiles and/or using the scale tool. By using the walk tool, you can generate a realistic representation to show what each design would look like going around a mantel, window, door, cabinets, or room. With all the vantage points covered, it's possible to plan details as simple yet as important as where a field joint would work best and how molding profiles will meet.

Use the scale tool to change the size of part of a profile without changing the shape.

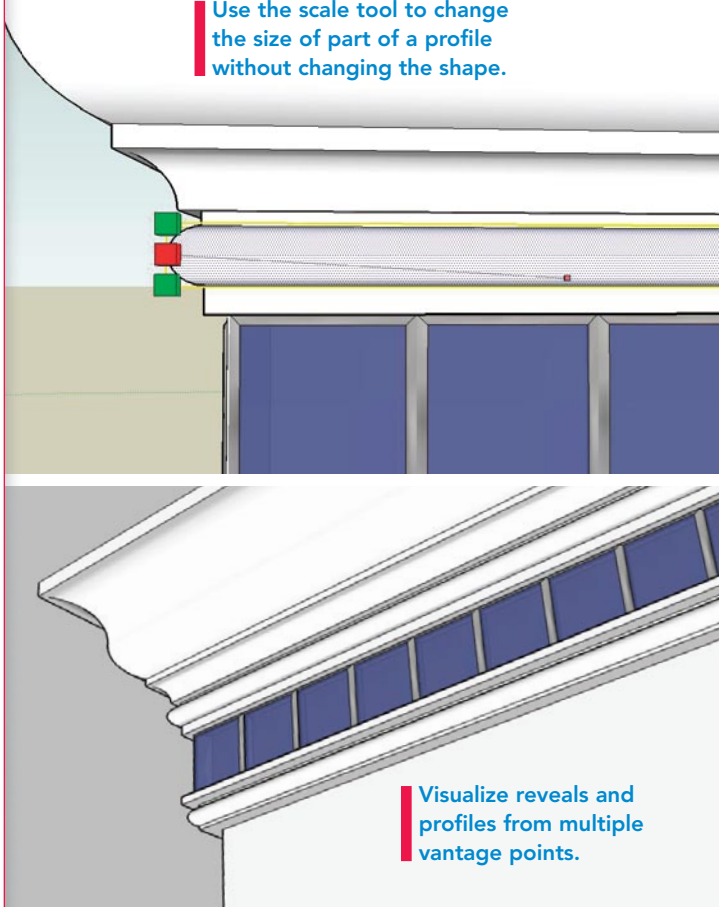

Visualize reveals and profiles from multiple vantage points.

MEASURE CIRCLES AND ARCS

To find the radius of a given arch, enter the width and height of the arc. The entity-info dialog box will show the radius. Draw a circle with a given radius, draw a chord through it, and measure the length of the arc. While these calculations can be done with a construction calculator, being able to visualize them is a reassuring benefit.

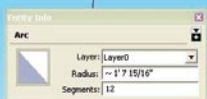

Find the radius of an arched opening automatically by using its height and width.

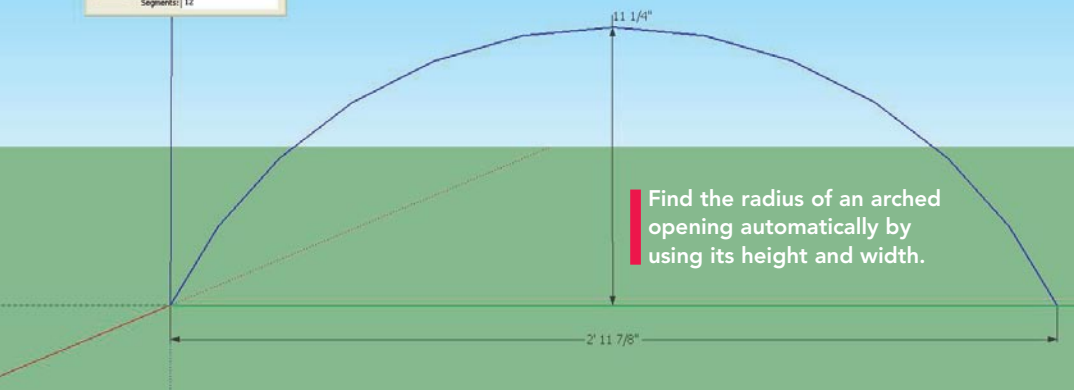

“overlay” of various design configurations and present them for evaluation.

In the past, this meant generating a pencil sketch of the space and drawing in the options. It was cumbersome to do variations on the design because it meant erasing and redrawing on the sketches with each change, leaving the paper more smudged and less accurate. And of course, the process took an incredible amount of time. Clients have appreciated the ability to view an actual room with overlaid design options side by side to choose features, colors, and proportions.

It's a visual construction calculator

It goes without saying that accurate calculations are important to good carpentry. Construction calculators allow for quick, accurate, complex calculations. But they require being on the job site, which isn't always the best place to be doing complicated math (especially when the weather is less than ideal). Plus, calculators can be pricey.

I have found SketchUp to be the next step in the progression of construction-math capability. For me, the greatest benefit is that calculations are visual.

Always a challenge, math for stairways is greatly simplified: With a given rise dimension, I can easily do two or three run scenarios to evaluate all the related clearances for headroom with railing height, length, and angles for code-compliance issues, and so on.

Invest the time, and reap the rewards

As intuitive as SketchUp is, it takes time to learn. There are some excellent free video tutorials online. Aidan Chopra's tutorials on YouTube (www.youtube.com/user/aidan_chopra) provide guidance on each of the tools found in SketchUp as well as slick shortcuts that make complex models easier to create. I found these tutorials invaluable in adapting to the digital job-site environment.

Each time I pick up a cordless drill, I wonder how I got by without it. SketchUp is such an accurate tool for resolving job-site design, planning, and calculating issues that it leaves me wondering how I got by with just a stubby pencil for so long. I'm still waiting to find a free, cordless board stretcher, though. □

Matt Jackson is a builder in Rapid City, S.D. Photos and drawings by the author, except where noted.