

# Router Bits I Can't Live Without

A veteran trim carpenter reveals his favorites along with a few of the jigs that make them so handy

BY JIM CHESTNUT

**W**hen I go fishing, I carry a tackle box that holds hooks, leaders, flies, and lures, all in hopes of out-witting a few creatures with brains half the size of a pea. Without the box, I might as well stay at home with a ham sandwich, watching reruns. When I work as a finish carpenter, I bring a similar box, but instead of hope, hooks, and Hula Poppers, this box contains the items that make my router the most versatile tool I own: router bits.

I've collected more of these tough little bits than I care to count. I use them for everything from trimming laminate counters to installing door hardware to making custom moldings. Out of desperation, I've even used them in my machine shop. When I broke a tool on a Sunday, I decided to substitute a 1/2-in. bullnose router bit in a vertical milling machine. It shaped approximately 6000 lin. in. of cold-rolled steel in one pass, without lubricant, before it chipped—when I dropped it on a concrete floor as I removed it from the machine. This may sound like a testimonial for reckless behavior (I assure you it's not), but it demonstrates the versatility of router bits.

Out of the hundreds of bits on the market, I've chosen an even dozen to talk about here because of their proven utility. I've also included a few tips that I hope will help you on that upcoming finish-carpentry job. □

---

A trim carpenter with more than 30 years' experience, Jim Chestnut now manufactures miter clamps in his Holden, Maine, shop. His Web site is [www.miterclamp.com](http://www.miterclamp.com). Photos by Charles Bickford.



## What's a better bit:

Since the introduction of commercial plunge routers, 1/2-in.-shank router bits have become the norm for most router work. Mounted in tables, routers with large cutters are performing work previously reserved solely for shapers. This shift could not have been made with 1/4-in. shanks. With nearly four times the mass and twice the circumference, a 1/2-in. shank requires far less than half the tightening

## Quick, perfect hinge mortises, every time

This is the simplest jig, just two pieces of  $\frac{3}{4}$ -in. plywood screwed together and clamped onto the door. The cutout is the same size as the hinge (in this case, a  $2\frac{1}{2}$ -in. cabinet hinge). Screwed to the cutout block, a perpendicular fence registers the template against the door's edge. If the door's edge has a back bevel, I'll re-create that angle in the template so that the mortise is cut parallel to the door's surface. I used a



**$\frac{1}{2}$ -in.-dia. pattern bit** chucked into a laminate trimmer to cut each mortise, a task that takes about two minutes to complete. This method works just as well for entry doors.

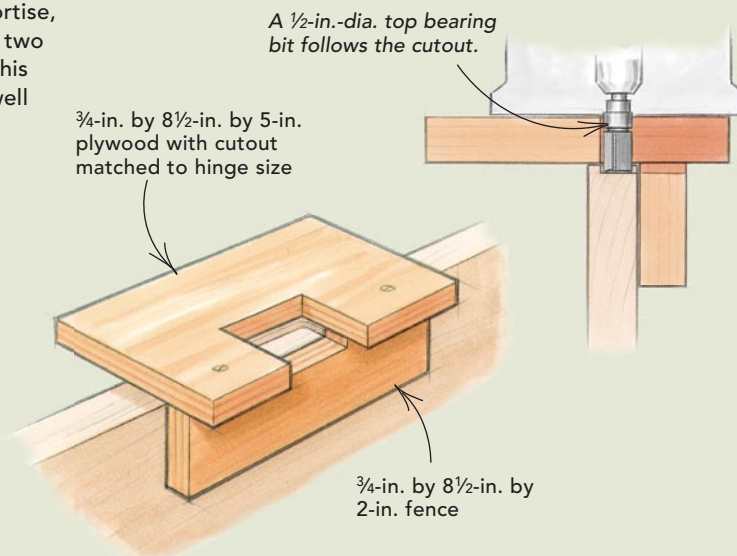

## $\frac{1}{4}$ -in. or $\frac{1}{2}$ -in. shank?

torque to prevent slippage compared to a  $\frac{1}{4}$ -in. shank of identical cutting profile. Also, a typical  $\frac{1}{2}$ -in. shank fits directly into the router's collet holder without the need for an additional collet. And the strength difference is astronomical.

So why not just eliminate  $\frac{1}{4}$ -in. shanks altogether? For one thing,  $\frac{1}{2}$ -in. shanks won't fit in laminate trimmers, and there's always a need for small detail bits.



## STRAIGHT BITS

Straight-cut bits come in a variety of configurations and diameters. Available with or without guide bearings, these everyday workhorse bits can be used for dadoing, rabbeting, flush-trimming, drilling, and mortising.



**$\frac{1}{2}$ -IN.-DIA. PATTERN BIT**

As a rule, I use  $\frac{1}{2}$ -in.-shank bits. They're easier to install, and I think they're safer. But of all the straight-cutting bits available, the one I use most frequently comes only in  $\frac{1}{4}$ -in. shank. This  $\frac{1}{2}$ -in. pattern bit has a  $\frac{1}{2}$ -in. bearing on the shaft above the cutter. Cost: about \$20.



**$\frac{3}{4}$ -IN.-DIA. FLUSH-TRIM BIT**

It's also essential to have  $\frac{1}{2}$ -in.-shank flush-trim bits with bottom bearings for flushing and trimming laminate counters or butted outside corners, and for trimming against any template mounted on the bottom of a workpiece. Again, I go with the largest diameter available. This particular bit, from Velepec, is made for solid-surface work and has a Teflon bearing. Cost: about \$45.

Straight bits, continued on p. 96



## STRAIGHT BITS (CONTINUED)



### 1 1/8-IN.-DIA. PATTERN BIT

I also frequently use a giant pattern cutter with a 1/2-in. shank and 1 1/8-in. cutting diameter. Its large cutting radius minimizes tearout and eliminates router burn; also, the bit is more stable and quieter than smaller cutters. Even when I'm routing along tricky or varied grain, I get smooth cuts with this bit. It's also ideal for trimming the laminated edges of solid-surface countertops. The bearing is guided by the top layer and cuts off the excess glue line below. Cost: about \$50.



### Outlet holes in baseboards become a mass-produced item with a template

Similar to the hinge-mortise jig, the jig for cutting outlets into baseboards consists of a simple two-piece template used with a 1/2-in.-dia. pattern bit



and a plunge router. The jig's fence registers the template against one edge of the baseboard stock; the template pattern is cut with a jigsaw or tablesaw to the exact outlet-box dimensions. The cut in the baseboard is made in at least two passes: first a light pass, then a deeper second pass that cuts through the stock.

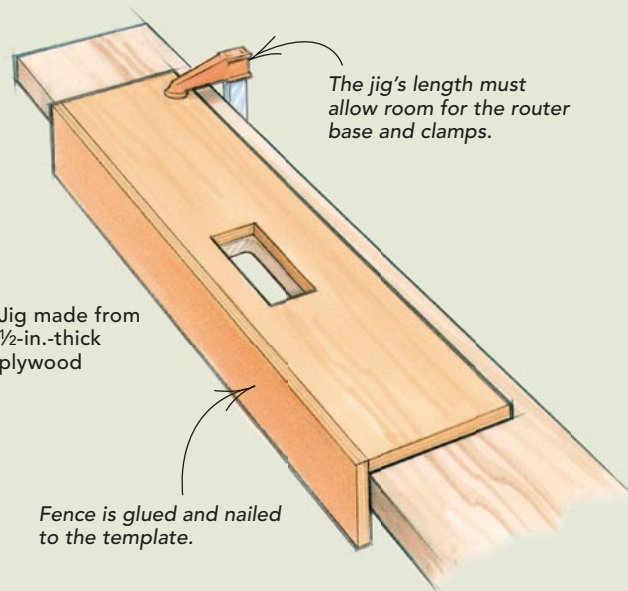

The jig's length must allow room for the router base and clamps.

Jig made from 1/2-in.-thick plywood

Fence is glued and nailed to the template.

### ROUTER-BIT SOURCES

You can buy router bits almost anywhere, but after lots of trial and error, I've found some manufacturers that I think make better router bits. Here's the contact information.

#### Velepec

Fred M. Velepec Co. Inc.  
71-72 70th St.  
Glendale, NY 11385  
718-821-6636

#### Whiteside

www.whitesiderouterbits.com  
800-225-3982

#### CMT

www.cmtusa.com  
888-268-2487

#### ONLINE VENDORS

##### Connecticut Saw & Tool

www.ctsaw.com  
800-404-1220

#### Central Coast Saw Inc.

www.carbide.com  
888-701-9278

#### RouterBits.Com

www.routerbits.com  
888-811-7269

## Straight bits make shelf joinery almost invisible

For bookshelves or cabinet boxes, dados are often not only stronger and better-looking than butt joints, but they're also much faster. If I'm working with  $\frac{3}{4}$ -in. plywood, I use a fence or ripped stock as a straightedge and cut a  $\frac{1}{2}$ -in.-wide dado just a hair deeper than  $\frac{1}{4}$  in. using a  **$\frac{1}{2}$ -in.-shank straight bit** (photo above right). Next, I cut a  $\frac{1}{4}$ -in.-deep rabbet into the mating case bottom or top with a **rabbet bit** (photo right). The rabbet is set to fit semi-snugly into the dado; too tight a fit will cause a kink in the case side. The router leaves no tearout, and the joint disappears, regardless of varying thicknesses of the plywood. A word of caution: This technique can cause cabinets to shrink mysteriously by  $\frac{1}{2}$  in. after assembly.

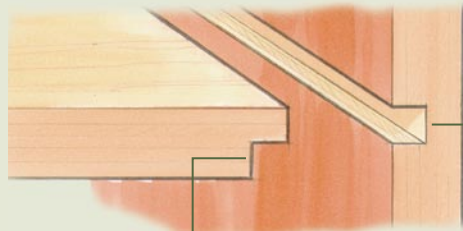

### **$\frac{1}{2}$ -IN.-DIA. STRAIGHT BIT**

These  $\frac{1}{2}$ -in.-shank bits are handy for cutting dados and just about everything else. I also use them to cut deep mortises with a plunge router or, in a fence to cut rabbets. Cost: about \$20.



### **$\frac{1}{8}$ -IN.-DIA. RABBET BIT**

Rabbet bits often are sold with an assortment of different-size bearings that make the bit adaptable to different jobs. This  $\frac{1}{2}$ -in.-shank bit is among the largest available and, consequently, is able to cut a wider range of rabbets. Cost: about \$65.



### **$\frac{1}{4}$ -IN.-DIA. SPIRAL BIT**

Available in both up- and down-cutting spirals, this type of bit is ideal for plunging into stock. The down-cutting spiral bits tend to create less tearout but feel to me as though they're pushing the router away from the stock. I prefer the up-cutting spirals. Cost: about \$15.



## Shelf-pin jig is faster than drilling

The shelf-pin jig looks like a ladder made of two 2-in.-wide strips of  $\frac{1}{2}$ -in. plywood; strips of  $\frac{1}{4}$ -in. plywood make up the rungs and determine the spacing of the shelf-pin holes. I use a plunge router fitted with a  $\frac{1}{2}$ -in.-dia. guide bushing and a  **$\frac{1}{4}$ -in.-dia. spiral bit**. The jig is built so that the bushing fits neatly in each space between the two pieces of  $\frac{1}{2}$ -in. plywood.



The width of the  $\frac{1}{4}$ -in. crosspieces determines the holes' intervals.

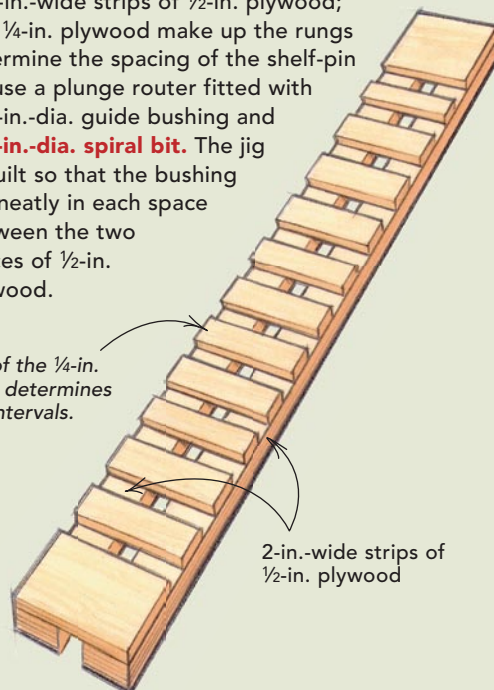

2-in.-wide strips of  $\frac{1}{2}$ -in. plywood





## PROFILE BITS

Although usually meant for one task only, specialized profile bits are just as useful as straight bits and are invaluable for making custom moldings and reproducing old trim.

### **5/16-IN.-DIA. BEADING BIT**

I like to keep a good supply of beading bits on hand. My favorite is a 5/16-in.-dia. bit with a 1/2-in. shank, whose proportions give a pleasing detail to 3/4-in.-thick stock.

A simple bead can add real class to otherwise plain shelving units or cabinet face frames. Cost: about \$30.



### **3/8-IN.-DIA. ROUNDOVER BIT**

Because roundover bits describe a nearly perfect quarter circle, they mill a more rounded nosing than bullnose bits.

Roundovers can be run from both sides of the stock to accommodate nearly any thickness. I make shoe moldings, quarter-rounds, door and window stops, outside-corner moldings, and eased edges. The roundovers also work well for bullnosing tops, chair-rail caps, and crown shelf. Cost: about \$30.



### **1/2-IN.-DIA. CORE-BOX BIT**

Given a choice between bearing-guided cove bits and core-box bits, I choose the latter. A 1/2-in.-dia. roundnose bit used with a fence can produce exactly the same profile as a 1/2-in. cove bit with a bearing. But it also can cut flutes for pilasters, stress-relief grooves for the backs of wide stock, scotia, and whatever else you can dream up. A cove bit with a bearing will produce only a cove on the edge of the stock. Cost: about \$40.



### **Make a stable base for routing**

When I'm running small profiles, such as with this 5/16-in.-dia. beading bit,



I usually clamp several boards together from the bottom so that the router base can run on a wide platform. Running on a single board edge is not only extremely dangerous, but it's also a great way to ruin a piece of stock.

### **Routing tapered flutes with the aid of a simple ramp**

For me, it was impossible to make a stopped-flute pilaster without router-terminated flutes that show in stain-grade work. Fortunately, I prefer the look of tapered terminations that also don't turn brown, which I make with a 1/2-in.-dia. core-box bit. I rip two pieces of scrap slightly narrower than the pilaster so that they don't interfere with the router fence and bevel them at about 50° on my chopsaw; I then screw them to each end of the stock. After marking the flute layout on the stock, I set the router fence for the first flute and always start with a less-than-full-depth cut on the first pass. I draw a highly visible square line just before and after the termination points of the first flute that helps to keep the successive flutes square. I always make sure that all the required pilasters, plus two extra, have been fluted prior to a fence change.



A square plywood base keeps the router parallel to the stock as it descends the ramp.

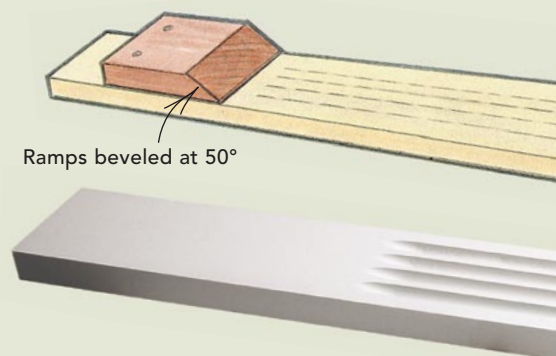

## A profiled sill is sturdy

Cutting and gluing a mitered return on the end of a window stool, chair-rail cap, crown head cap, and the like can be fussy and time-consuming. Instead, I usually prefer to rout a profile on the ends. The process is faster, and I don't have to worry about a tiny mitered piece falling off in a



year or two. For best results and for a safer rout, do this type of work with a **1/2-in.-shank window-stool bit** in a router table.



## 1/2-IN.-SHANK WINDOW-STOOL BIT

The profile of the window-stool (also known as a sill) bit starts as a bullnose, then stops short and flares into a cove. This traditional look is particularly useful when the sill is adjacent to wainscot walls. The sill's bullnose is squared off below, making an easy transition to the apron, especially important in paneled areas already packed out a distance from the wall plane. This bit has no guide bearing, so it works best in a router table. But I also use it with part of the profile "buried" in a wood fence attached to the base of the router. Cost: about \$50.



An extralarge fence keeps the router parallel to the stock.

Stopped flutes often burn.



Tapered flutes are more elegant.

## 1/2-IN.-DIA. PILOT PANEL CUTTER

When I lived out West, I saw framers cutting out rough openings with a router and a pilot panel cutter. The bit's spade tip cut through the sheathing, the shaft formed a rub collar that followed the studs, and the cutter cut the sheathing. It's an extremely fast and clean way to cut sheathing—definitely my kind of tool. Cost: about \$25.



## MULTIPROFILE BIT

Another molding detail that I like is the nose and cove found on many multiprofile bits. Stock milled with this profile can be used as a shelf nosing that extends below a 3/4-in. plywood shelf to hide from view the bottom joint that's often susceptible to tearout. The shelf edge's rounded top edge is less prone to nicks and dings than a hard edge. I like to glue the appropriate-size stock to the shelf material, sand flush, then rout and trim. That same nose and cove can be used as neck molding, band molding, and small bed molding. Cost: about \$65.

