

Laying out for Framing

A production method for translating the blueprints to the wall plates

by Jud Peake

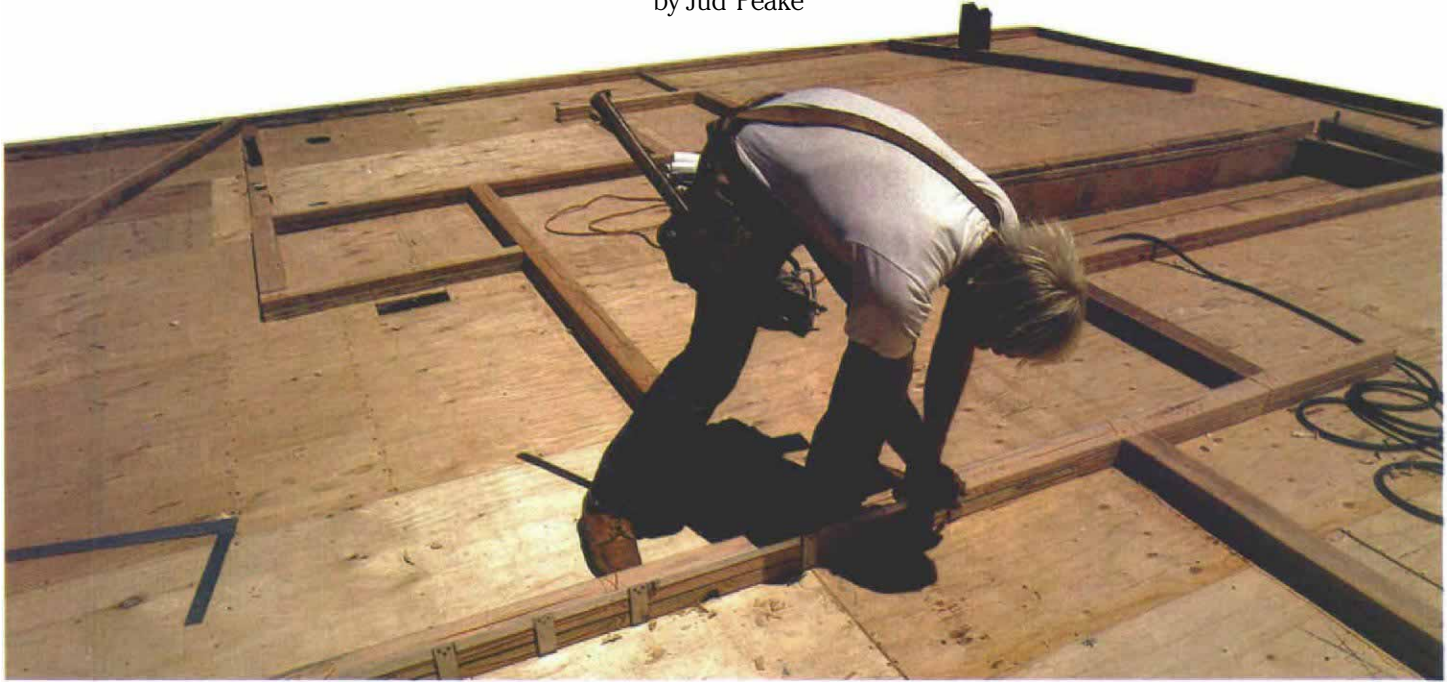

On big production projects where jobs are highly specialized, the carpenter assigned to layout uses a hammer very little. His tools are a lumber crayon (known in the trade as keel), a pencil, a layout stick, a channel marker and a tape measure. If he marks the top and bottom plates correctly, the carpenters may not even need a tape measure to frame up the walls. All of the figuring that involves the plans—and there are a lot of variables to anticipate—is done at the layout stage.

On large jobs, I don't necessarily frame the house I lay out. On houses I contract, I do both jobs. Either way, I treat layout as if there won't be anyone around to answer questions when the framing starts. Doing the layout as a separate operation increases the speed and accuracy of framing, whether you're building your own house by yourself or working as part of a big crew. The plans are an abstraction of the building to be constructed. Layout systematically translates your blueprints into a full-size set of templates—the top and bottom plate of each interior and exterior wall on a given level of the house. The pieces of the puzzle can then be cut and framed in sections.

There is little about a finished house that isn't determined by the layout. The actual procedure falls into four distinct steps. Within each step, you have to deal with wall heights

and the locations for windows, doors, corners, partitions, beams and point loads. You also have to deal with *specials* (which is anything else and usually means prefab components).

The first step in layout is to go over the blueprints and mark them up with the information you'll need, in the form it will be most useful. Step two is to measure out the slab or deck and establish chalklines representing every wall on that level. This is called *snapping out*. In step three you'll decide where walls begin and end and which ones will be framed first, and then cut top and bottom plates for each wall. This is called *plating*. Finally you *detail* the plates by marking them with all the information the framer will need to know to build the walls. Layout requires a thorough knowledge of framing. But even then, regional framing techniques vary widely.

Layout principles—Layout is based on parallel lines. If two lines are parallel and one is plumb, then the other will be plumb. Also, if a pair of lines meet at a right angle, then another pair of lines, each parallel to its counterpart in the first pair, will meet at a right angle. Stated less theoretically, put a 2x4 on top of another 2x4 and cut them to the same length. Using a square, draw a line across the edges of both every 16 in. Frame in between

these top and bottom plates with studs of equal length, and stand the wall up and plumb one end. Now all of the studs will be plumb. Doors and windows that have been laid out with these studs will be plumb. And if your foundation and deck are square and level, then any interior walls paralleled off the outside walls will also be square and plumb.

The second principle is to do all the layout at once. This way all the plates are fitted against each other, and you can be confident that the walls will work together before they grow vertically and become unmanageable.

The third principle is my own: avoid math. You can do most of your figuring in place. If you're looking for the plate and stud lengths of a rake wall (one whose top is built at the pitch of the roof it supports), snap it out full scale on the deck. Measure things as few times as possible. Once the walls are mapped out on the deck in chalk, don't measure them and then transfer this number to the plate stock sitting on sawhorses. Instead, lay the plate material right on the line and cut it in place. This saves time and reduces error—the kind that has to be fixed with a cat's paw.

Marking up the plans—Before you step out on the slab or deck, you need to go over the blueprints and systematically pick out the ele-

Marking up the plans

The first step in laying out is to add to the floor plan any further information needed to detail the plates later on. You need to write in the header length for each door and *tt* if it will require double trimmers. Windows show two numbers—the header length and the height of the sill jacks. You also need to mark beam pockets and the point loads under them, rake walls, and the locations of non-standard stud and header heights. The last notation is the direction the stud layout will run.

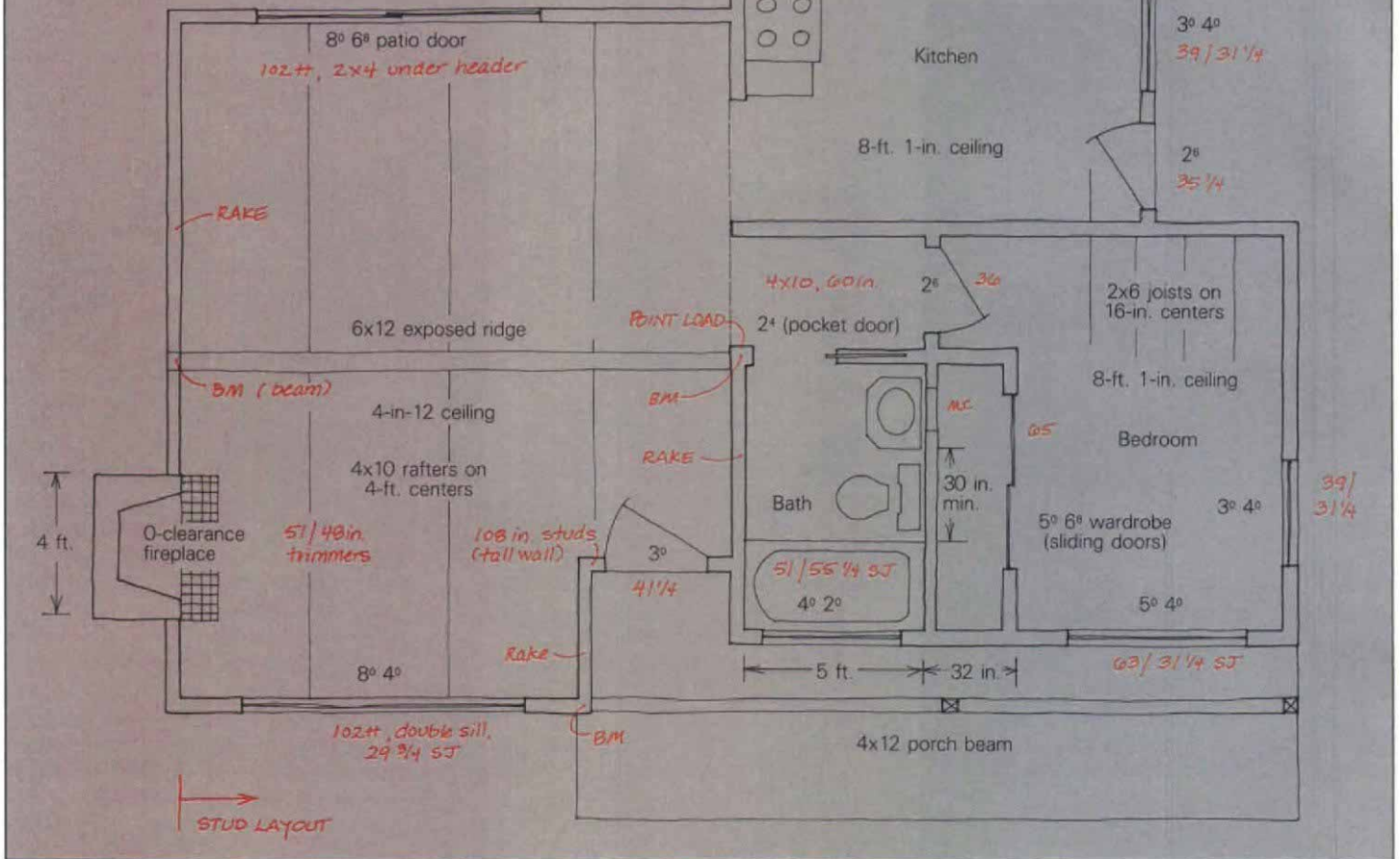

ments that should be part of the layout. I do this in the evening when I can slow down my pace a little bit. Thumb through the drawings just to review the general structure. Read the rough and finish carpentry specifications, and underline anything that isn't standard.

Next, go back to the first-floor plan in the blueprints. Write on the plans, next to the appropriate opening, the length of each door and window header. This will allow you to measure out and mark them on the plates later on without having to stop and figure, and will also allow whoever does the framing to make up a list and cut all of the header stock, sills and sill jacks at once. See the facing page for what these framing members are, and how to figure their lengths.

The drawing above shows a blueprint that contains many of the framing situations you will encounter. I'll use these same plans in explaining snapping out, plating and detailing. In this case, the blueprint is marked up with the necessary information for laying out. For doors, only the header length is written in; when nothing else is noted, this indicates a standard 6-ft. 8-in. door in an 8-ft. wall.

In the case of the aluminum patio door in

the living room, a 2x4 is needed to fur the header down to the right height. The *tt* next to the header length indicates double trimmers for this 8-ft. opening. The pocket door to the bathroom shows the length of the header, and its narrower width (4x10). Windows show two numbers: the first is the length of the header, and the second is the length of the sill jacks.

With the exception of the rake walls, which will be snapped out full scale on the deck, I have marked the only wall that doesn't use standard 8-ft. studs (the jog in the living room) with the notation *108-in. studs (tall wall)*. With a hodgepodge of elevations, it helps to mark up the plan view with colored pencil to differentiate stud heights.

The plans have also been marked for beam pockets (*BM*) on both ends of the ridge beam in the living room, and where the porch beam bears on the exterior wall. Resulting point loads (where significant loads have to be carried down to the ground) also have to be marked. The interior end of the ridge beam might not be picked up below without a notation. Also, studs should be doubled under joists that will be doubled on the floor above.

You'll also need to mark the dimensions of

any prefabricated items that will go into the house, like a medicine cabinet or roof trusses. (When using trusses, the building width can always err slightly on the narrow side, but don't ever make it too wide.)

One of the last things you'll want to note on the plans is at which end of the building you'll start the regular stud layout. The decision is yours. The side with the fewest jogs or offsets in the exterior walls is usually the place to start. When you reach a jog, compensate with the stud layout so that the studs, joists and rafters (or trusses) all line up, or *stack*. If the plans call for 2x6s on 2-ft. centers with trusses, code requires that they stack. It's a good idea anyway, both for increased structural strength, and for making multi-story mechanical runs like heat ducts easier.

In the drawing, I decided to pull my layout from the bottom left corner. By beginning there, the studs will pick up the rafter layout in the living room (exposed 4x10s on 4-ft. centers) and will work well with the ceiling joists and the porch overhang. You can also write down the cumulative dimensions of rooms, so that when you're snapping out, you'll be able to mark all of the intersecting

The Pieces to the Puzzle

An introduction to the components of a modern frame and how to size them

If you've done some framing, it takes only a second of looking at the detailing on a set of plates to know what the wall will look like when it's framed and raised. After that it takes only a pencil and a 2x4 scrap to make up a cut list of headers, sill jacks, rough sills, trimmers, channels and corners. But if you're new to how all of this goes together, you'll need to understand the different framing styles and the many exceptions created by using different kinds of windows, doors and finish.

Below I've explained how the basics work. Since I learned my framing in the West, my explanation will focus on how it's done there using basic production techniques, but I'll also point out more traditional methods as I go along.

Stud walls—Studs (2x4s or 2x6s on 16-in. or 24-in. centers) hold up the roof or floor above, and provide nailing surfaces at regular intervals for the interior and exterior finish. Precut studs are 92¼ in. long and are used to build a standardized 8-ft. wall that works economically with standard plywood and drywall sizes. The actual height of this wall is 8 ft. ¾ in. once you add 1½ in. each for the *bottom plate (sole plate)* that sits under the studs, and the two *top plates* (the *top plate* and the second top plate, called the *double top plate* or *doubler*) that complete the wall. Architects sometimes add to the confusion by specifying this same wall as 8 ft., 1 in. Wall studs are seldom shorter, but where economy isn't as important, they are often longer. If walls are over 10 ft., they will require *fire stops*—horizontal blocking that slows down the upward spread of fire.

To find stud height, check the elevations and sections in the blueprints. What will be listed here are wall heights, usually shown as finished floor to finished floor (*F.F. to F.F.*). In most cases, you can use the same dimension for rough floor to rough floor. To figure the stud length given this dimension, subtract 4½ in. (the thickness of the three plates), plus the subfloor thickness and joist depth.

Rake walls—These are also called gable-end walls, and they require the framing to fill in right up to the bottom of the pitched roof. This means that each stud will be a different length and will be cut at the roof pitch on top. Typically, a rafter will sit on the top of these walls. There are two ways to frame them. One is to build the lower part of the wall just as you do the walls under the eaves of the roof and then fill in the gables later. This is fine if there is a flat ceiling at the 8-ft. height. The other way is to build the wall in one unit with continuous studs. This is necessary for cathedral ceilings. See p. 73 for the specifics on figuring lengths and angles.

Wall intersections—When one wall intersects another, the framing has to provide a solid nailed connection between the two walls, and backing for the interior finish. The drawing above left shows how this is usually handled. Money can be saved by replacing backing studs with nail-on drywall corner clips, and by reducing corner units to a simple L, but there are disadvantages to these cutbacks.

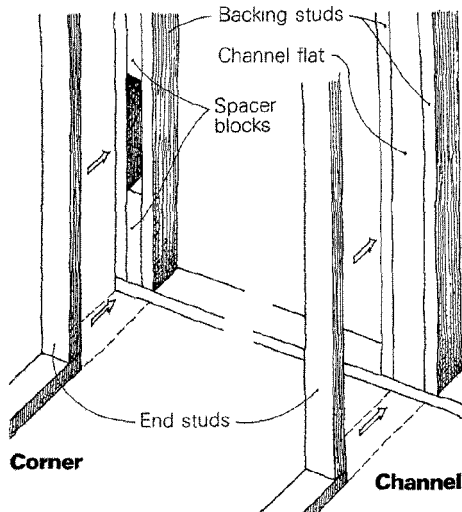

Doors—Door openings require *headers* to shift the weight of the roof in that area to both sides of the door. The vertical 2x support at each end of a header is called a *trimmer* (or *cripple*); the stud just outside of the trimmer that nails to the end of the header is called a *king stud*. The *rough opening* is the *rough-opening width*, measured between the trimmers, by the *rough-opening height*, which is measured from the floor to the bottom of the header.

Finding the height of the trimmers and the length of the header requires working backwards from the dimensions of the finished door. But you don't have to go through the full process each time—door headers should be 5 in. longer than the nominal width of the door. For example, a 37-in. header is needed for a 2-ft., 8-in. door. This 5-in. increment assumes that the trimmers will be framed very nearly plumb. Some carpenters use 5½ in. or even 5¾ in. to allow for sloppier framing.

Adding 5 in. to the header accommodates two 2x trimmers (1½ in. apiece, for a total of 3 in.) under the ends of the headers (drawing, above right). This leaves a rough opening 2 in. wider than the door. The remaining room is for two 1x side jacks (¾ in. apiece, for a total of 1½ in.), and ½ in. for shim space. (This leaves ¼ in. on each side.) Allow another ½ in. for exterior doors whose rabbeted jacks are closer to ⅝ in. thick, French doors will require closer to ½ in. of extra header length to account for the astragal (the vertical trim between the two doors that acts as a closure strip). If the door opening is wider than 8 ft., then the trimmers will need doubling, which requires another 3 in. of header length.

In the West, it's common to use 4x12 Douglas fir header stock in all 8-ft walls. This system is fast, because all the framer has to do is cut the stock to length and nail it to the top plate—there are no *headjacks* to toenail, and you end up with a header at the right height that will span almost any opening. This system is admittedly wasteful, but gets around the cost of labor. Fir is still relatively inexpensive in large hunks, and the labor to cut and install the head jacks isn't.

If you aren't using 4x12s, check a span table for the correct header size (unless you are dealing with a non-bearing interior wall, where two flat 2x4s will do nicely). Typically, when

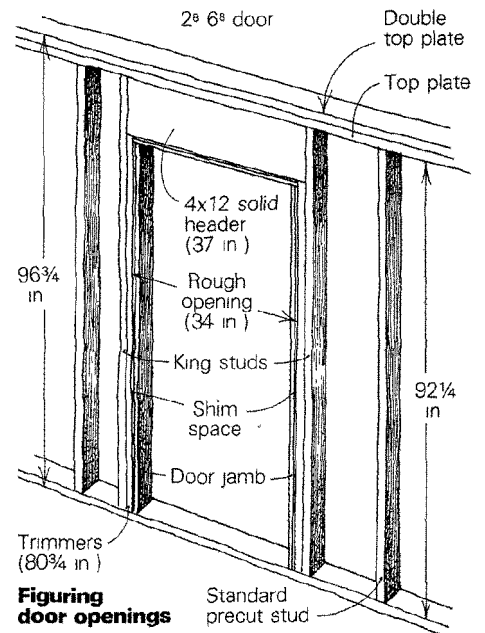

solid headers aren't used in 2x4 bearing walls, the choice is a laminated header made on site from two lengths of 2x with ¾-in. plywood sandwiched between. Using either system, if a wall exceeds 96¾ in. in height, head jacks (cripples) will be needed between the header and the top plate.

Using a standard 6-ft. 8-in. door, the trimmers should be cut 80¾ in., no matter how tall the wall is, or what kind of header you use. Once the bottom plate is cut out within the doorway, this will leave a rough-opening height of 6 ft. 10¼ in. This height will accommodate the door (6 ft. 8 in.), the *head jamb* (¾ in.), and enough play for the finish floor and door swing. An aluminum patio door requires 1½ in. of furring under the header. Pocket doors and some bifold doors require an extra 2 in. of rough-opening height for their overhead tracks. In an 8-ft. wall, a 4x10 held tight to the top plate works nicely. Even if you are not using solid header stock, you'll need trimmers that are 82¾ in. for these doors.

Windows—A rough window frame is like a door opening with the bottom filled in—that's just how you frame one. The rough width of a window is measured between the trimmers. The rough height is measured from the bottom of the header to the top of the *rough sill*. This is a flat 2x, doubled if the window is 8 ft. or wider, that runs between the inside faces of the trimmers. Unless it's otherwise noted on the plans, windows are framed with the same height trimmers as the doors.

In some areas of the country, the trimmers are installed in two pieces (*split trimmer*, or *splitjack*) with the rough sill cut 3 in. longer and sandwiched between (see *FHB* #15 p. 43). If double trimmers are used, then the inside pair can be framed this way. Underneath the rough sill, the stud layout is kept by *silljacks* (or *cripples*) which are in essence, short studs.

Finding the length of the rough sills and the sill jacks is fairly simple. Depending on how you deal with the trimmers, the length of the rough sill will be the same as the width of the

Figuring rough window openings

Wood windows used to be specified by lite sizes such as the double-hung 32/22 (two lites, each 32 in. wide by 22 in. high) at right. But these days, you are more likely to get a unit size like 37¼ in. by 53¼ in. (which includes sash and jamb allowances), or better yet, the rough opening of 38¼ in. by 53½ in. (which also includes the space for shimming). These numbers will allow you to figure the header, sill and sill-jack lengths so that the window will fit.

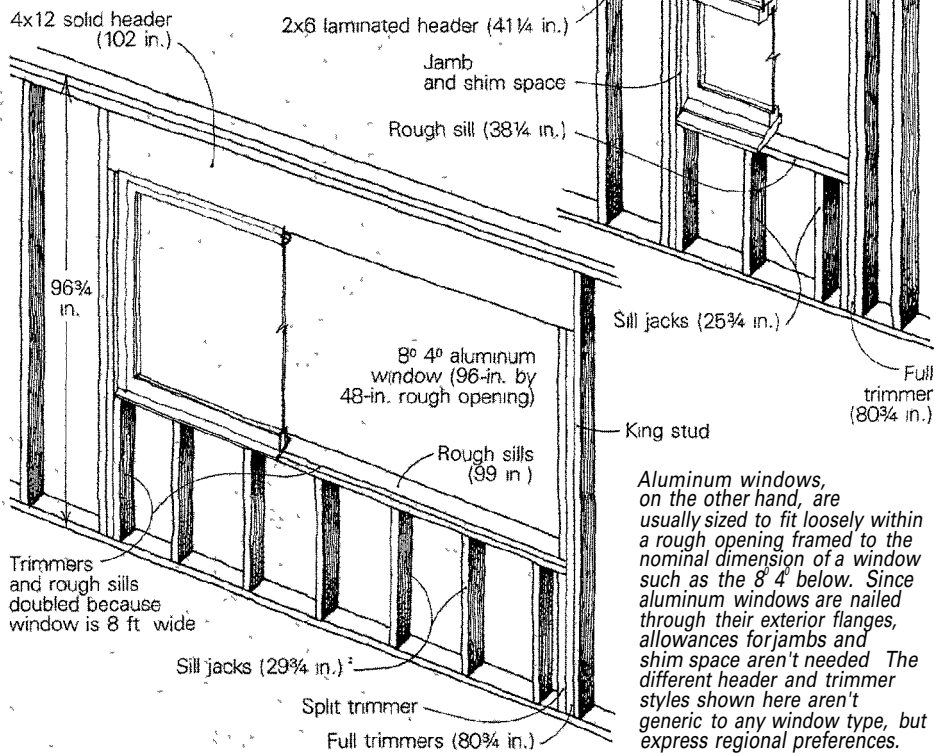

rough opening or 3 in. longer. To get the length of the sill jacks, add the rough opening height to the thickness of the rough sill, and subtract this from the height of the trimmer.

The length of a window header has a lot to do with what kind of window will fill the hole—aluminum or wood. To get the header length on an aluminum window less than 8 ft. wide, just add 3 in. to the nominal window width to allow for a trimmer on each side (drawing, above). This is because aluminum windows are generally manufactured to fit loosely in a rough opening of their nominal size. Check with your supplier to be safe. The first number stated for windows (and for doors) is the width—a 3' x 5' aluminum window needs a rough opening 36 in. wide and 60 in. high. For windows wider than 8 ft., you'll need to use double trimmers, which will increase the length of your header 3 in.

Wood windows were once specified by the size of the lite, or glass, which didn't account for the sash or frame that surrounded it. The rules of thumb about how many inches to add to the sash to get the rough-opening size are quite general because the width of stiles and rails differs among manufacturers. The rules are also specific to window type (double-hung, single or double easement, sliders, awning and hopper) since the number and width of their stiles and rails vary.

Today, most manufacturers' literature gives a unit dimension (this includes sash and frame) and a rough opening dimension. Use the rough-opening measurements for laying out, and add 3 in. to get the correct header

length on windows under 8 ft.; 6 in. over 8 ft. If the rough-opening size isn't specified in the plans or by the manufacturer, you've got to measure the windows on site. If they are set in jamba, add 3½ in. (two trimmers plus ½ in. for play) to get the correct header length; if not, add 5 in., as you would for a door.

Specials—This catchall category includes any member or fixture in the frame that's big enough to worry about. Medicine cabinets and intersecting beams are *specials*. Toilet-paper holders aren't; they can be dealt with later.

Your main concern with most specials is to provide backing for the interior wall finish, and a break in the regular stud layout if an opening is required. Beam pockets are simple. Imagine a ridge beam that is supported on one end by a rake wall. There are a number of ways to frame the bearing pocket for the beam, but any of these schemes should include a post or double stud beneath the beam, and backing on either side of it for nailing wall finish or trim.

Tubs, showers and prefab medicine cabinets require both backing and blocking. Blocking is what it sounds like—short horizontal blocks or a 2x let into the studs for nailing the wall finish. Backing is usually an extra stud and does the same thing only vertically. In the case of a corner bathtub, then, the line of blocks that sits just above the lip of the tub where the drywall will be nailed is the blocking. At the end and side of the tub where the wallboard will butt, you'll find an extra stud for backing. —Paul Spring

Snapping out. Facing page: Peake uses his foot to anchor one end of the chalkline while snapping out a short exterior partition. The red keel X by his right foot tells the framer on which side of the line to nail down the wall once it's raised. This project was unusual because the exterior walls were framed, sheathed and raised before the interior was laid out.

interior walls along one side of the building by pulling the tape from just one point rather than having to do this room by room.

Snapping out—Snapping out isn't much more difficult than redrawing the architect's floor plan full size on the deck. Using a chalkbox, you need to snap only one side of each wall and draw a big X with keel every few feet on the side of this line that the wall will sit.

Measure for the outside walls first. Come in 3½ in. (for a 2x4 wall) or 5½ in. (for a 2x6 wall) from the edge of the deck. Be sure to measure from the building line, not from the edge of the plywood, in case it's been cut short or long. Don't even trust the rim joists without checking them with a level for plumb, since they may be rolled in or out.

Snapping lines should go quickly. To hold the end of your string on a wood deck, just hook it over the edge of the plywood, or use a nail or scratch awl driven into the deck. If the slab is very green (poured less than a week before), a drywall nail will usually penetrate the concrete; if not, use a concrete nail. You can even hold the string with one foot if the wall that you're snapping is short (photo facing page).

On very long walls, especially on windy days, have someone put a finger or foot near the middle of the line and snap each side separately. This will keep the chalkline truer. If you're working alone, close the return crank on the chalkbox to lock it and hook it over the edge of the deck so it's secure on both ends.

I use red chalk for layout. Lampblack also shows up well, but blue isn't a good choice in my area because it's the favorite of plywood crews. When I expect rain or even heavy dew, I use concrete pigment (Dowmans Cement and Mortar Colors, Box 2857, Long Beach, Calif. 90801) instead of chalk. If you're doing a lot of layout, get yourself a couple of chalkboxes with gear-driven rewind; if you've made a lot of mistakes, correct them with a different color chalk. When it comes to keel, I use red mostly; blue has a way of disappearing.

In snapping out the exterior walls, don't be concerned about intersecting lines where the walls come together. This problem will be solved when you do the plating. Just concentrate on getting the lines down accurately. Once you've done that, check the lines for square by measuring diagonals, and check the dimensions again carefully. On slabs and first floors, check to see that where you have put the exterior walls will allow the siding to lap over the concrete for weathertightness.

I usually snap out rake walls on the deck (sidebar, facing page). This will let the framer cut the studs in place between the chalklines, once again avoiding math. Make sure that you

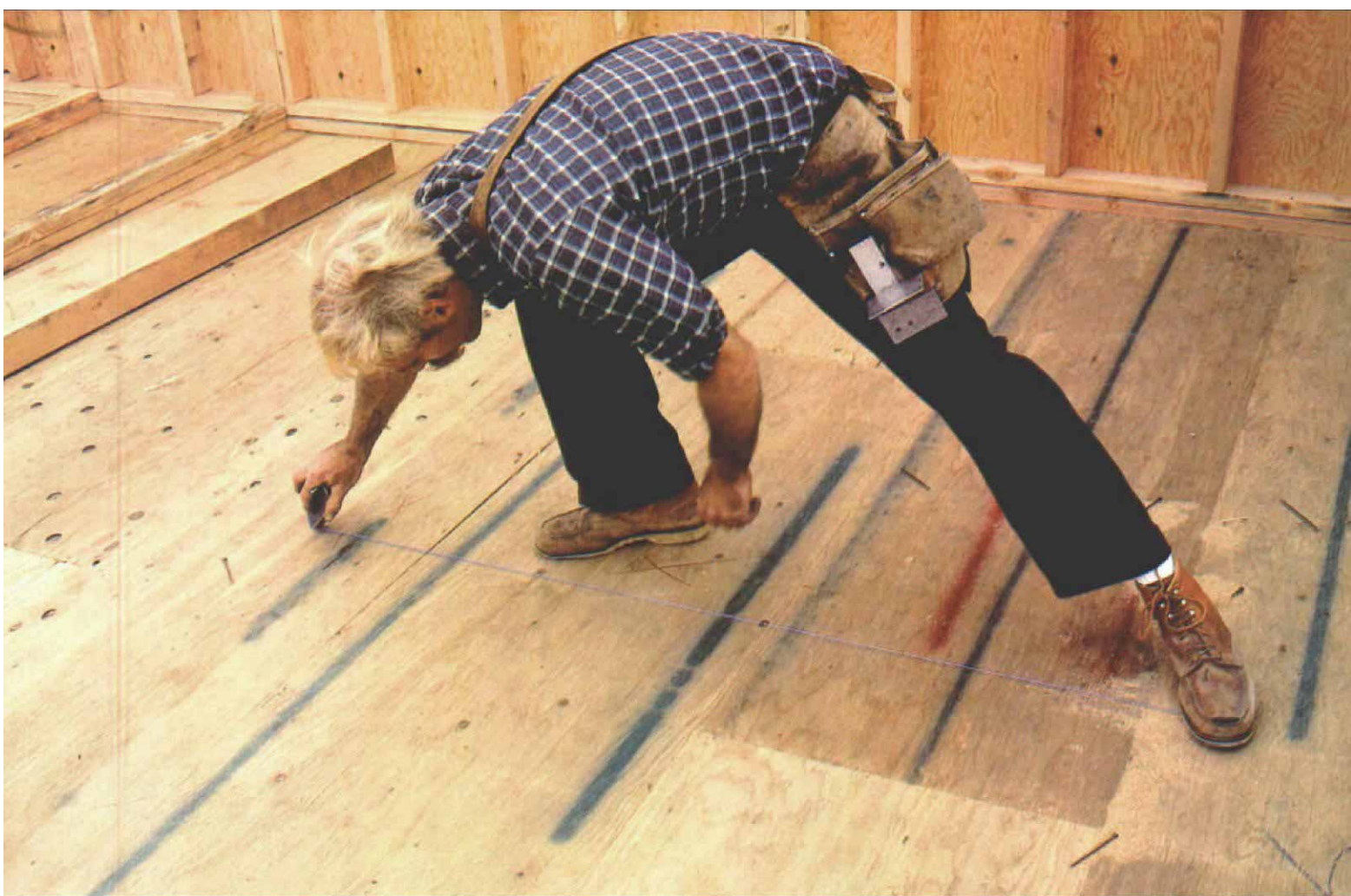

Rake walls

Rake walls are fairly simple to plate and detail if you snap them out full scale on the deck, and keep in mind how they will relate to the rafters that will eventually sit on them. The bottom plate of the wall will look like any other. The trick is locating the top plate so the framer can fill in the rake-wall studs without doing any calculations.

In this case the rake wall will intersect a standard 96 $\frac{3}{4}$ -in. wall. The first real complication is dealing with the bird's mouth on the rafter. With 2x4 walls, I use a 3 $\frac{1}{2}$ -in. level cut so that the rake wall dies into the 8-ft. wall at the top inside edge of its double plate. This also allows me to measure the run of the rake wall from the inside of the 8-ft. wall to the near face of the ridge beam. In this case, that's 10 ft. Since the pitch is 4-in-12, the rise between those points is 40 in.

Now back to the deck. Measure along the 8-ft. wall, 96 $\frac{3}{4}$ in. from the chalked *baseline* of the rake wall. This baseline was snapped out like the other wall lines as a guide for positioning the inside edge of the bottom plate once the wall is framed and raised. But it is also a convenient starting point for the full-scale elevation of the rake wall that you are going to snap out on the deck. In this case, it will be used to represent the bottom of the bottom plate.

The next step is to lay out the

bird's mouth of the rafter above the 96 $\frac{3}{4}$ -in. mark you just made along the 8-ft. wall. Then take two pieces of 2x scrap and lay them inside the line at approximately a 4-in-12 pitch to represent the rake top plates. The reason you use two pieces of 2x scrap instead of just subtracting 3 in. for the rake top plates is that the vertical thickness of these plates when they are at a pitch will be greater than when they are horizontal. In the case of a 4-in-12, two plates add up to about 3 $\frac{1}{4}$ in.

Now make a mark on the chalkline of the 8-ft. wall just below the two scraps. This point represents the top (short point) of the shortest stud in the rake wall, and will be used to establish the line of the rake top plate. To complete this line across the deck, you need to create a large 4-in-12 triangle. In this case, a 4-ft. leg and a 12-ft. leg work out nicely. Actually, this triangle can be any size as long as its proportions are correct, it is close to the length of the rake wall, and it is positioned so that its hypotenuse represents the bottom of the rake top plate.

To lay out this triangle, first make a mark on the rake baseline 12 ft. out from the inside of the 8-ft. wall. From this point, measure up 93 $\frac{1}{2}$ in. (the height of the 8-ft. wall less the thickness of the two top plates) parallel to the 8-ft. wall, plus another 4 ft. to take care of the rise. Now use a snapline to connect

this point with the one on the 8-ft. wall that you established below the scrap top plates. This is the hypotenuse of the 4-in-12 triangle, and as the bottom edge of the rake top plate it will be used by the framers to cut the tops of the rake studs to length.

To establish the top end of the rake wall, find the point along the rake baseline that represents the near face of the ridge beam. When the rake wall is framed, the top plates will die at the top inside face of this beam. Now snap a line that is parallel to the 8-ft. wall that starts at this point on the rake baseline and ends by intersecting the rake top plate line you just snapped in the center of the deck.

To check your layout, you can use your tape measure to get the height of the longest stud in the rake wall at its long point. Do this by measuring along the chalkline you just established at the inside face of the ridge beam. Stretch your tape from the baseline of the rake wall to the bottom of the top plates, and then subtract 1 $\frac{1}{2}$ in. for the bottom plate. This measurement should be the same as the shortest stud plus the rise of 40 in. that was figured earlier.

To finish up, determine the position of the ridge beam by laying out the bird's mouth at the top. By subtracting the depth of the ridge beam, you can also determine the length of the posts beneath it.

—J. P.

Standing rake wall

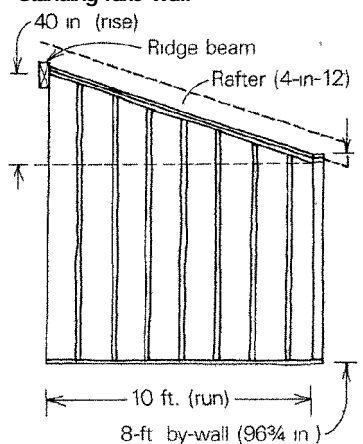

Deck layout

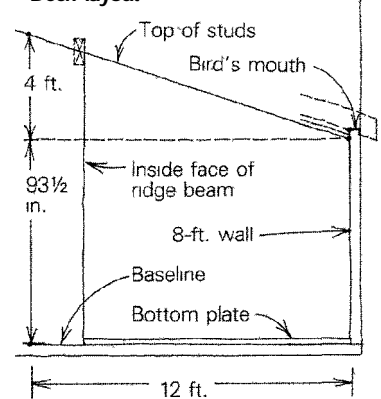

Plating the deck

All of the plates here above have been cut and tacked flat on the deck. This way they check themselves by butting tightly at every intersection. To get to this point, you have to decide which walls run by, and which ones butt. By-walls are framed first, and the longest walls are typically chosen for by-walls. Usually, parallel walls are then designated as by-walls. Rake walls should be framed as butt-walls, and this leads unavoidably to one living-room wall being plated log-cabin—one end running by and the other end butting.

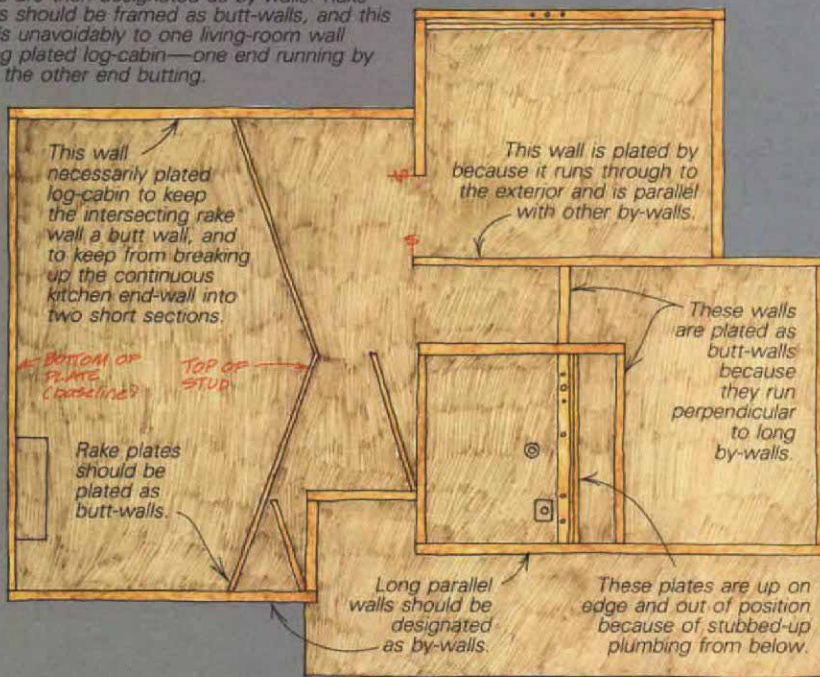

let the framers know with directions in keel whether your lines represent the top and bottom of studs, or the plates themselves.

Once the exterior walls have been chalked out, snap the interior walls by paralleling them (measuring out the same distance from several points and connecting them). When a wall ends without butting another wall, indicate where with a symbol that looks like a dollar sign with a single vertical bar. Follow the written dimensions given on the blueprints. Before you use an architect's scale to get a missing dimension, make sure that you can't find it by adding and subtracting others. If a mistake is made—whether it's yours or the draftsman's—you're the one who's going to fix it. Yet it's always better if what you've done reflects the approved plans.

Occasionally, though, you will have to adjust room sizes to accommodate some unanticipated condition. The rule of thumb here is to adjust in the largest rooms. The sizes of smaller spaces are usually dictated by the building code or some prefabricated item.

Plating—Plating involves cutting a top and bottom plate for each wall, tacking them together and laying them in place on the deck. To do this, you must decide at each intersection of walls which ones run through (*by-walls*) and which ones stop short (*butt-walls*). Walls that should be framed first—usually the longest exterior walls—are designated by-walls. Usually, the walls parallel to these will also be plated as by-walls. The framing and plating is simpler if you plate rake walls as butt-walls since the top plates are detailed in place (on their full-scale layout lines) near the middle of the deck. If plated as a by-wall, the top rake plate would lap over the plates of exterior walls that run perpendicular.

What you want to try to avoid in plating is *log-cabining*—building walls that run by at one corner and butt at the other. Such walls will probably have to be slid into position after they're framed and raised, which isn't easy, especially with a heavy wall.

The drawing top left shows the plating for this floor plan, and lists reasons why some walls have been designated butt-walls and others by-walls. Notice that the living-room wall at the top of the drawing has been plated log-cabin. So much for hard-and-fast rules. In this case, the rake wall at the end of the living room had to be a butt wall, and the kitchen wall on the other end had to run by so it wouldn't end up in two extremely short sections. The result is necessary log-cabining.

To do the plating, spread the top and bottom plate stock near the snapped lines. Use long, straight pieces. A crooked top plate can drive a framer crazy when it's time to straighten the raised wall with braces. To make the length on long walls, top plates will have to butt together at the center of a stud. The middle of a solid header is an even better spot. Breaks in the top plate and the double plate (the framer will be supplying this permanent tie between walls) have to be at least 4 ft. apart. That means to stay at least 4 ft. away

Two ways to plate mudsill bottom plates

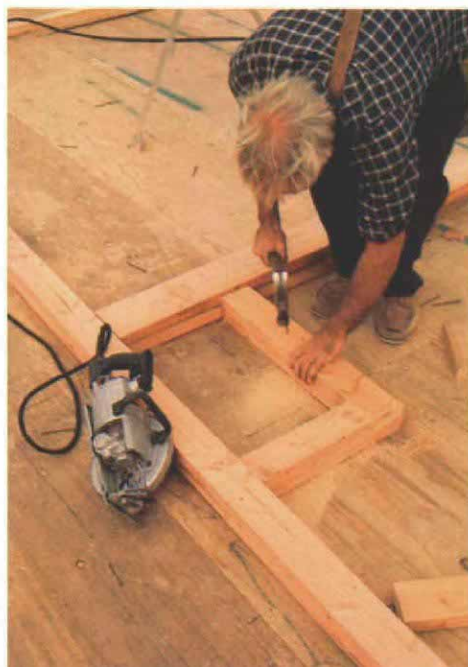
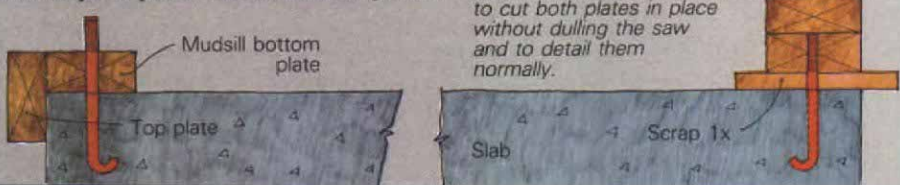

Plating. Peake cuts in the top and bottom plate of a small raceway (left), and tacks each of the two sets of plates together with 8d nails (right) so they can be detailed. One of the first decisions in plating is which walls will run by, and which will butt. Here the long interior wall is a by-wall, and the parallel wall of the raceway is plated the same way.

Peake pries apart the top and bottom plates on a small section of exterior wall that has to be framed separately because of stubbed-up plumbing. The layout carpenter must constantly be thinking ahead to the framing stages. How the house is plated, and which edges of the plates (inside or outside) the detailing is marked on will have a lot to do with how easily and quickly the framing will go.

from intersecting walls when laying out a break in the top plate, since the double plate of this wall will have to end there.

Very long walls will have to be framed in sections. With an average number of headers in an 8-ft. high 2x4 wall, each carpenter on the site should be able to handle at least 10 lineal feet of wall when it comes time to raise it. If you're going to break a long wall into separate sections, you'll need to end the top plate at the center of a stud. The bottom plate should be broken at the same place.

The plate stock for the bottom plate should be tacked flat to a wood deck along the snapped line with an 8d nail near each end. It's fine if it laps over nearby wall lines, because the next step is to crosscut it in place by eyeballing the chalkline of the intersecting wall. Now lay down the top plate in the same way, cut it and tack it to the bottom plate with two more 8d nails (photos facing page). The only exception to nailing the plates together is a rake wall where the top plate will be left on the deck on its angled layout line.

In the case of a slab, the bottom plate will be a mudsill. I use a bolt marker like Don Dunkley's (see *FHB* #19, p. 55). I usually make mine out of a piece of 1x2 with a joist-hanger nail at 3½ in. and at 5½ in. Once the mudsill is drilled out and set on the bolts, you have to deal with the top plate, which won't tack down to the mudsill because of the bolts.

Some carpenters hang the top plate off the edge of the mudsill (drawing facing page, center left), and then detail the layout across the edge of the top plate and the flat of the mudsill. But the framers will like it better if you shim up the mudsill with 1x scraps (drawing facing page, center right). This allows you to cut both the mudsill and the top plate in place without dulling your sawblade on the concrete, and to detail them normally.

Detailing—After all the plating is complete, detailing can begin. It is done in three stages: recording the information that you've added to the blueprints on the plates, marking out the precise measurements for headers, corners and intersecting walls on the face and edges of the plates, and then adding the stud layout. The drawing on the next page shows the floor plan with the plates fully detailed.

Layout style varies widely from region to region. One difference is in detailing shorthand. Layouts often contain more detailing than is really necessary. For instance, if you indicate where the end of a header falls with a line, and then make an X for the king stud beyond the line, it will be evident to the framer that the trimmer goes on the other side of the line. Writing *T* for trimmer (or *C* for cripple, de-



pending on the terminology you use) takes time, and doesn't add any information.

Another difference is the orientation of the plates. Some production carpenters tack the plates together and then toenail them along the chalkline with their edges up, rather than flat. But there are several advantages to running them flat. The first is that they check themselves. They can't be too long or too short because they are laid in the precise positions that they will occupy once they have been framed. Second, the location of headers and wall intersections is easy to see when it's detailed on the top of a flat plate, and won't get overlooked or misframed. Last, all the information necessary for the framers to cut the double plates that interconnect the walls is

marked on the surface to which they will be nailed—the top face of the top plate.

Almost all the marks that you'll put on the plates will be on the top of the top plate, and on one set of edges. The way to determine which set of edges is to approach a pair of tacked-down plates as if you are going to frame the wall. The trick is to figure out from which direction the top plate will be separated, the studs added and the wall raised. With an exterior wall this is easy. The top plate will be walked to the interior of the deck with its top markings facing the opposite side and its stud layout (which is on the edge) up. This way, once the vertical members have been filled in, the wall can merely be tilted up into place without having to reorient it. Exteri-

Detailing the plates

The last step in layout is to detail the tacked-in-place plates. First, the information from the plans is written on the tops of the top plate and one set of edges. This includes the length of the headers, sill jacks, non-standard trimmers and studs, and the drywall blocking for the bathtub and medicine cabinet. Header lengths are then measured, marked and squared across the plates with a channel marker. It's also used to mark corners and channels. For intersections of different height walls, PT is used instead of an X to indicate that the double top plate passes through. The last information added is the stud layout. It can be seen in pencil on the six callouts that show how the plate edges are detailed in particular cases.

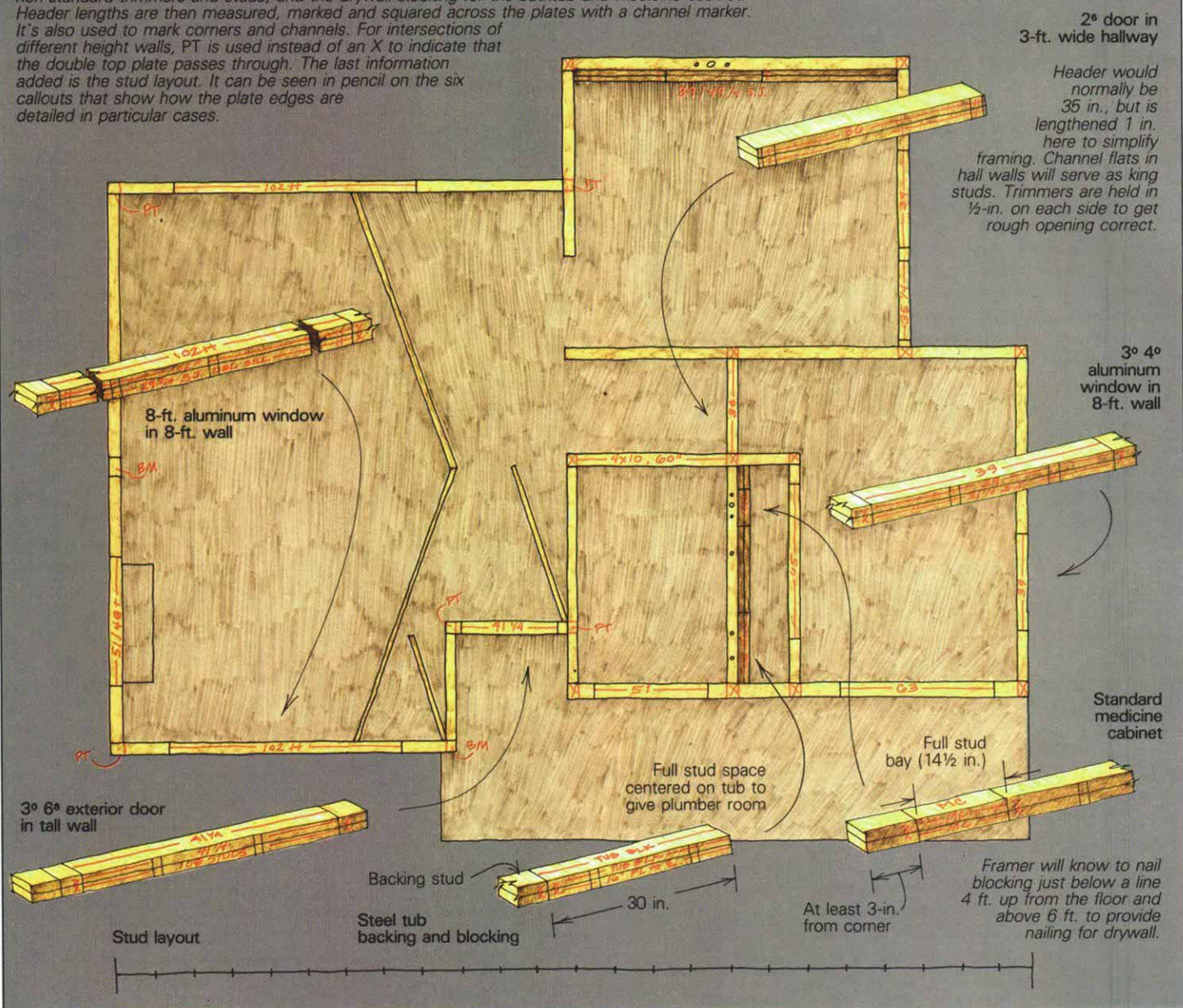

or plates, then, are typically detailed on their outside edges. Interior partitions, since they can often be tilted up from either direction, require the layout carpenter to guess how and where the framers will set up.

You're now ready to do the detailing. Forget your tape measure for the moment, take the plans in hand and walk around the deck copying the information you've written there onto the plates. For each window and door, write its header length on the top of the top plate near where the header will be nailed, and *tt* if it requires double trimmers. Now lean over the plates and mark the outside edge of the top plate with the same information.

As long as you detail the rough-opening dimensions of the windows on the plates when you lay out, you don't have to figure the height of the rough sill or the length of the sill jacks. The framer can do this by measuring

the rough-opening height down from the header; installing the rough sill, and then filling in with the sill jacks. However, if you figure the length of the sill jacks at the layout stage, they can be pre-cut for the framing. Write this length in keel on the outside edge of the bottom plate and follow it with the letters *SJ*. For any walls with studs longer than the standard $92\frac{1}{4}$ in., write their lengths on the face of the top plate and on the outside edge of one of the plates. Note the location of prefab items, like medicine cabinets (*MC*), and drywall blocking around fixtures like bathtubs (*TUB ELK*). Label rake walls *RAKE*.

At this point you can begin to mark corners and channels on the top and edges of the plates. Both of these are just wall intersections—one at the end of a wall, one in the middle—and are drawn the same width as the plate stock. When these intersections are

framed, they'll need backing studs for wall finish, but since corners and channels are usually made up as units that include their backing studs, you need only to show the intersection of the plates for the framer to get it right.

To detail the corners, use a pencil to scribe a line onto the inside edge of the by-wall plates along the side of the butt-wall plates. Then use a channel marker (see the box on the facing page) to continue that line across the face of the top plate and down the other edges. These lines will show exactly where to nail the walls together once they are framed and raised. Channels aren't much different from corners, except you have two lines to scribe—one on each side of the intersecting plates. Put a big keel X between the lines on the face of the top plate, and on each of the outside edges of the plates to show where the double plates of the intersecting wall will cre-

ate a half-lap. If the walls connect at different heights, the double plates of the by-wall shouldn't be broken for the double plate of the butt wall. The framer should be warned by marking the corner with the letters *PT*, which tell him to *plate through*.

A common framing mistake, usually discovered after the wall is raised, is putting the flat stud of the channel on the wrong side of the wall from the intersecting partition. As long as the framer knows the flat-plating method used here and doesn't reverse the top and bottom plates, where to locate the flat will be obvious. The key is the *X* that marks the channel. Because you are prevented from making any marks on the inside edges of the by-wall plate when you scribe the butt-wall plate to it by the plates themselves, the *X* will get marked only on the opposite set of edges from where the intersection will actually happen. So the framer should nail the channel flush with the edge of the plate that doesn't have an *X*.

Now detail the window and door openings. Following the blueprints, measure accurately to each end of the headers and use your channel marker to square the lines across the top plate and down the outside edges. Make an *X* on the outside of each of these lines to indicate the king stud.

When making an *X* over the edges of the plates, you can save yourself an extra motion by making two intersecting half-circles. This will leave an *X* on each plate when they are separated. The only time I show the location of trimmers is when they are doubled, which I indicate with *tt* (see the 8° 4' living-room window callout in the drawing, facing page).

Interior doors are often placed near the corner of the room they serve. The standard way to frame them is to let the king stud act as one of the backing studs in the channel, compressing space. Once the drywall is hung, this leaves a little less than 3 in. for casing. If the casing is wider than this, it will have to be scribed to the wall. If the space is even narrower and the door is in a butt-wall such as the 2-ft. 6-in. door in the 3-ft. hallway in the plan, you'll have to use the channel flat as a king stud. A useful rule of thumb is that the space left for the trim is about the same as the distance from the studs of the intersecting wall to the inside face of the trimmer.

There are a few special items in bathrooms that need detailing. The medicine cabinet fits between studs, but it will need blocking above at 6 ft. off the floor and below at 4 ft. If the medicine cabinet is near a corner, double the end stud that nails to the channel to give the necessary room for the swing of the cabinet door. Bathtubs and showers should be blocked along their top edges. Detail this by specifying a height on the plate that runs from the floor to the centerline of the blocking. A double stud or flat stud should be laid out to pick up the side and end of the tub or shower. In the drawing, you can see that I've also centered a standard stud space on the plumbing end of the tub to make it easier for the plumber to run supply lines and a drain.

Beam pockets can be detailed with your

channel marker, but label them *BM* so they are not confused with channels. The posts under these beams are detailed with their actual width marked on the edge of the plates with keel, and their nominal size written in between these lines. Also give a length for the post if it is different from stud height.

Stud layout—The regular stud layout comes last and is done on the outside edges of the plates. Pull all the outside and inside walls that run perpendicular to the joists and rafters from the same end of the building. Do not break your layout and start again at partitions, but continue the full length of the wall. The standard 16-in. and 24-in. centers are meant to work modularly with 4-ft., 8-ft. and 12-ft. sheet materials. Remember that 16 in. o. c. means from the end of the building to the center of the first stud, so reduce your layout by $\frac{3}{4}$ in. each time when pulling from the corner ($15\frac{1}{4}$ in. to the first stud, $31\frac{1}{4}$ in. to the second stud, and so on). This way the plywood sheathing and subfloor will work out with a minimum of cutting and waste.

It's a common mistake to have drywall on your mind when laying out studs. Drywall is relatively cheap, easy to cut, and can be bought in 12-ft. lengths. It should be at the bottom of your list of worries when laying out.

Stud layout should be done in pencil. If you are using a layout stick, you can put your tape measure back in your nail bag once you get started. Scribe along both sides of each finger of the layout stick to mark for the studs, then reposition it farther down the plate and repeat. If you aren't using a layout stick, stretch your tape the length of the wall and make marks at $15\frac{1}{4}$, $31\frac{1}{4}$, etc. Then come back with a combination square set at a depth of 3 in., square these marks down the outside edges of the plates, and make an *X* on the leading side of the line. Don't bother to draw a line for both sides of the stud, but don't lose your concentration either when making the *X*s. Putting them on the wrong side of the line will cause big headaches later.

Rake top plates can be laid out by stretching a tape from the by-walls they butt, but you'll have to hold the tape perpendicular to the by-wall and keep moving the end of it farther down the by-wall so that the stud centers on the tape will intersect the angled rake plate. A better method is to measure the distance between studs along the angled plate after marking the first few, and then use this increment to mark the studs thereafter.

The last thing to do before you leave the deck is to look over the tops of the plates and make sure that every room has a door in it (a common but embarrassing mistake), and that all the channels are marked. These marks are easy to spot because they are on the top of the plates. Finally, to get the framing off to a good start you can cut all the headers, sills, sill jacks, and specials, as you already have a cut list on the marked-up plans. □

Jud Peake is a contractor and a member of Carpenters Local 36 in Oakland, Calif.



Tools of the trade

Most production layout tools were born of necessity on the site and made with available materials on a rainy day. One such tool is the channel marker (middle photo), a simple square made out of short pieces of plate stock and used for outlining corners and channels. It should have a leg 3 in. long (the depth of two 2x plates) and another leg $3\frac{1}{2}$ in. long (the width of a 2x4). Both legs are $3\frac{1}{2}$ in. wide. I make a more durable version with aluminum flat stock that includes a $1\frac{1}{2}$ -in. flange at the top. By turning the square over, you can lay out the thickness of a stud with this flange.

Two more tools that will speed things up are a layout stick (top photo) and a keel/pencil holder (bottom photo). This last item is just a short piece of $\frac{1}{2}$ -in. clear plastic tubing that will take a carpenter's pencil in one end, and* your keel in the other. Layout sticks can be made out of standard aluminum extrusions riveted together. The $1\frac{1}{2}$ -in. wide and 3-in. long fingers on mine are laid out for 16-in. centers and 24-in. centers. I even threw a hinge into my stick so that it could fold up to fit in a standard carpenter's toolbox. —J. P.